



Convergence of Optical and Wireless Access Networks

Gee-Kung Chang

**Byers Eminent Scholar Chair Professor
School of Electrical and Computer Engineering
Georgia Institute of Technology
Atlanta, GA 30332-0250**

**OFC 2008 Workshop
San Diego, California**

February 25, 2008



Outline

- **Convergence of Broadband Networking**
- **Integrated Optical Wireless Access Networks**
- **Optical Wireless Signal Generation**
 - Up-conversion of optical wireless signal
 - Multi-band wireless signals
- **Optical Wireless Network Architecture**
 - Dual Services: Wired and Wireless
 - Wavelength Reuse for Full-duplex Connection
- **Technology Challenges**
- **Conclusions**

Broadband Networking Trends

Meet the needs of future end-to-end, dynamic and flexible Internet services



Convergence of Voice, Data, Video and Interactive Multimedia Services

Convergence of High Speed DWDM Metro and WAN Networks

Convergence of Wireless and Wired Networks

Opportunities of using 60GHz mm-Wave for Wireless Services

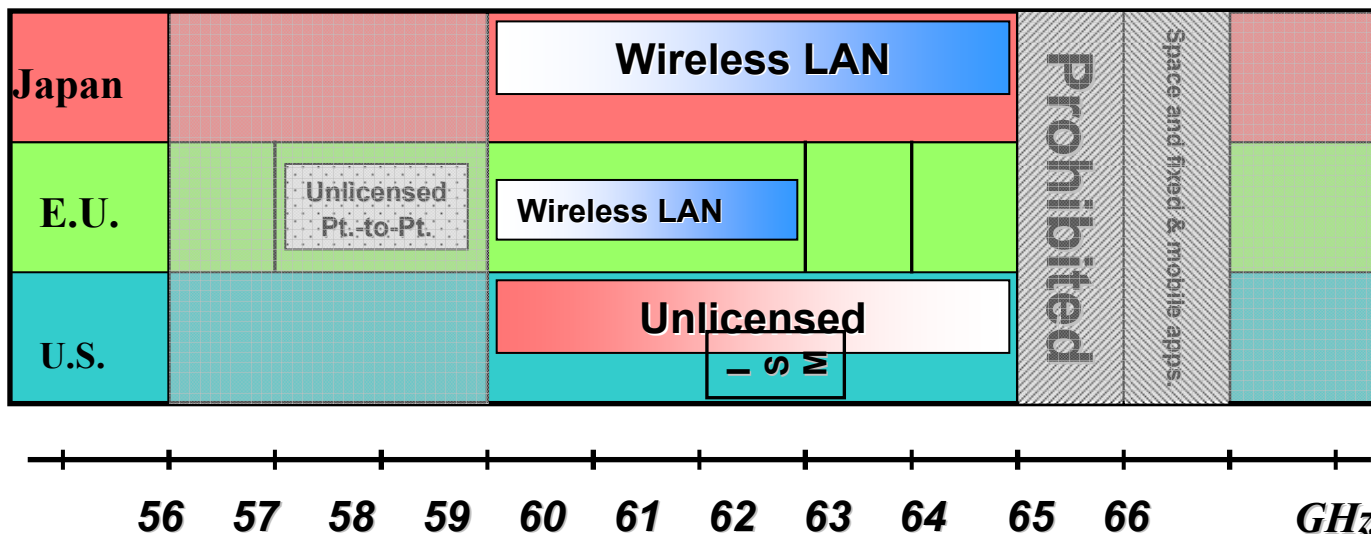

There is a license free band near 60GHz. There is up to 8 GHz antenna resonant bandwidth available for wireless communications.

It can provide super broadband wireless data links at > 1Gb/s.

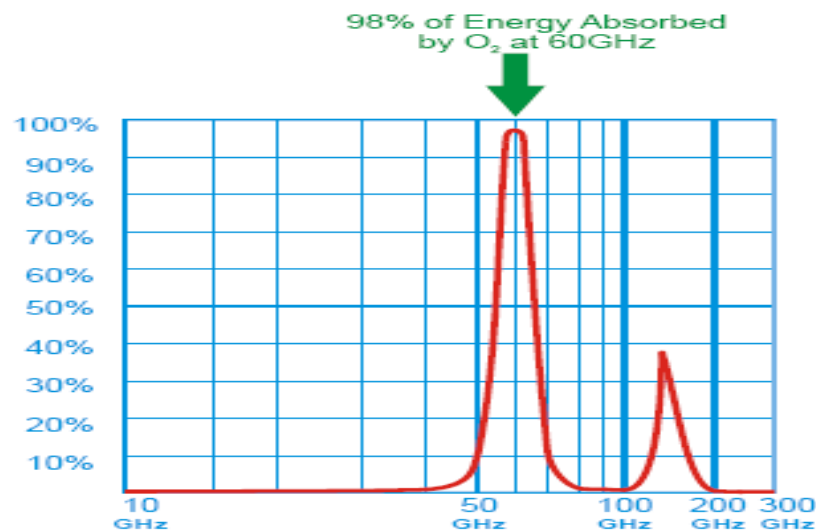

Convergence of Broadband Access Networks

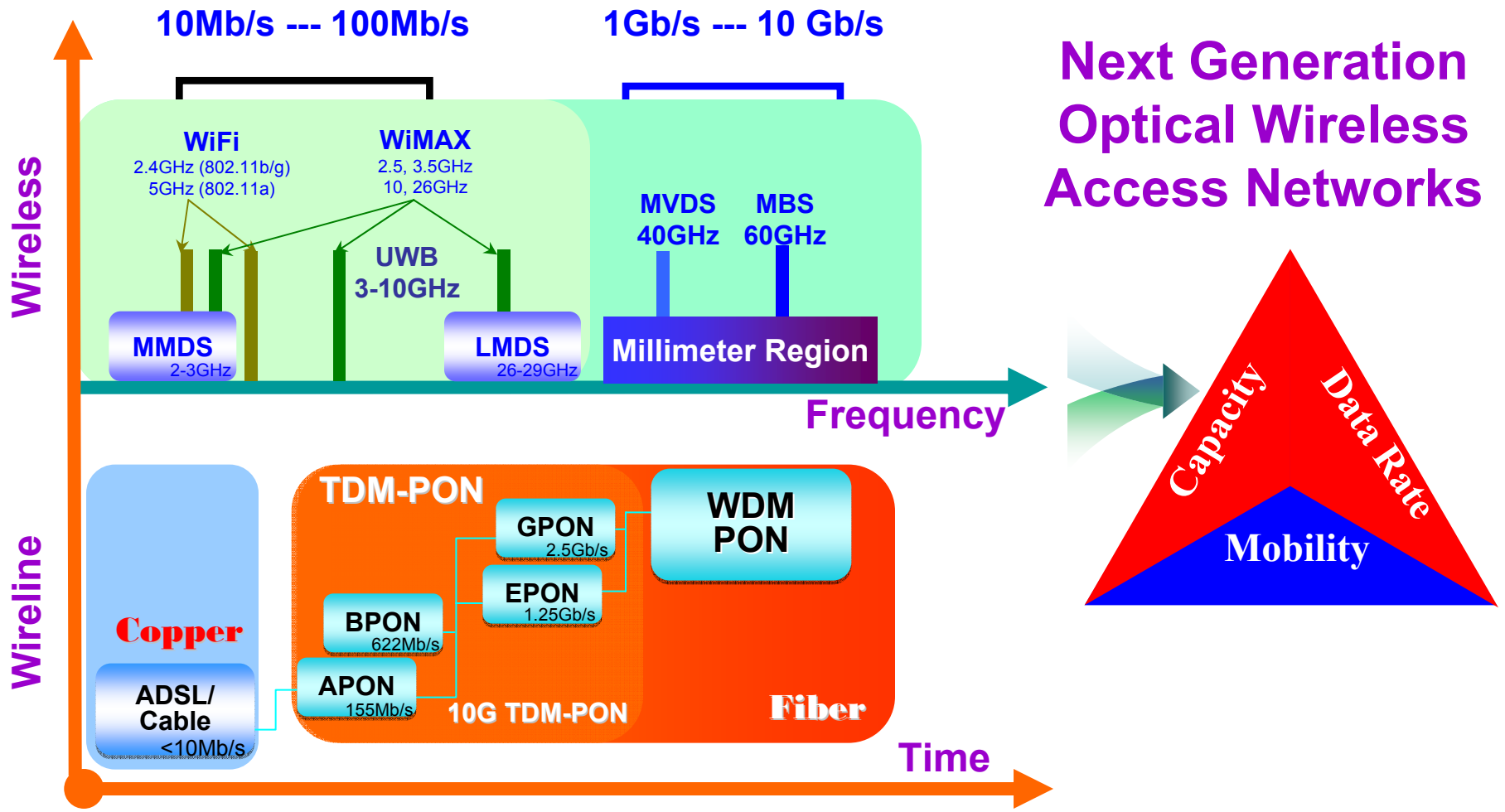

Emerging applications requiring super broadband optical-wireless access:

- HDTV distribution
- Interactive multimedia games
- High-speed wireless ($>1\text{Gb/s}$) data access
- High Mobility Communications
 - Base Station handoff
 - vehicle speed, bandwidth, and packet length

Wireless over Optical Transport Technologies

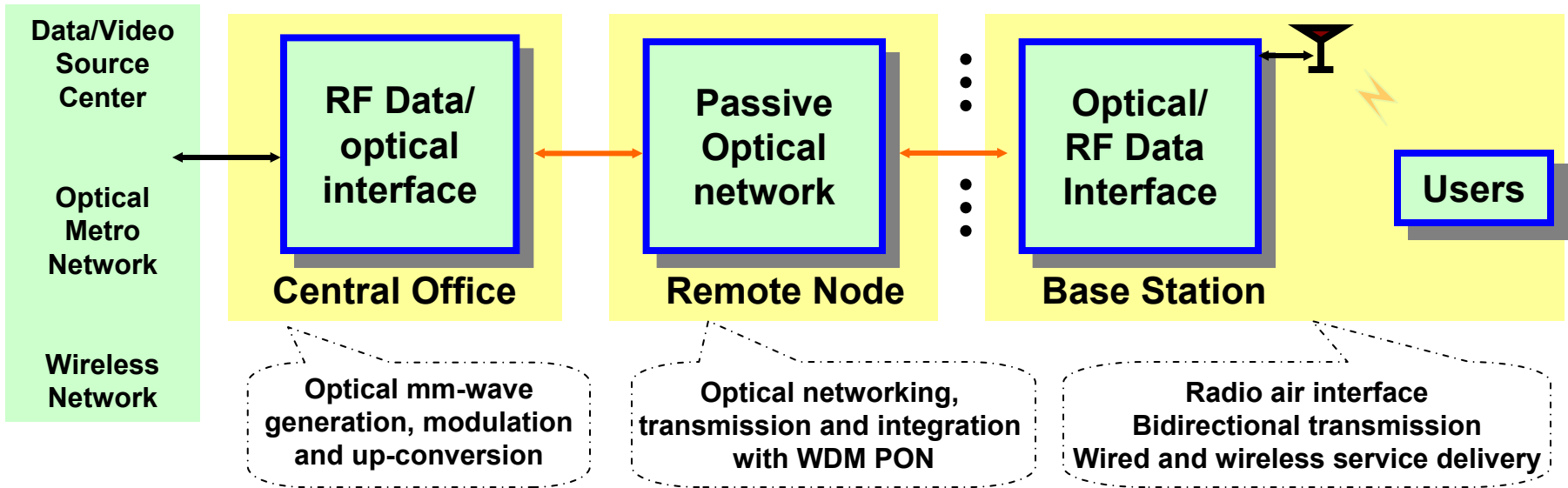

- **Bandwidth**
 - >1 Gb/s for both directions
- **Mobility**
 - RF wireless for roaming connection

- **Coverage**
 - Optical fiber links for long distance
- **Multi-channel Capacity**
 - Seamless integration with WDM PON
 - All-optical methods for architecture design

Spectrum of Optical Wireless Signals

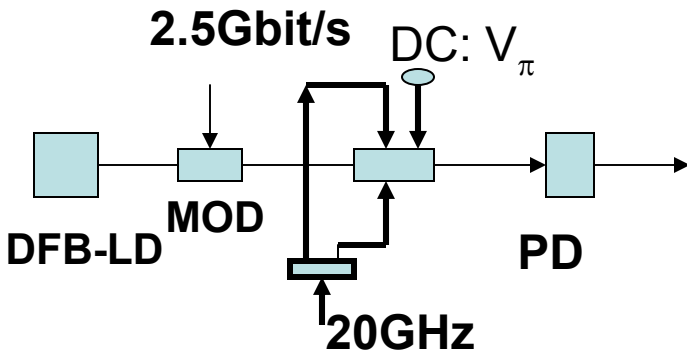

Dual Stage Modulation using
Optical carrier suppression

There are two components of
electrical signals after all-optical
up-conversion:

one part occupies the baseband,
the other occupies high-frequency
band near 40 to 60GHz.

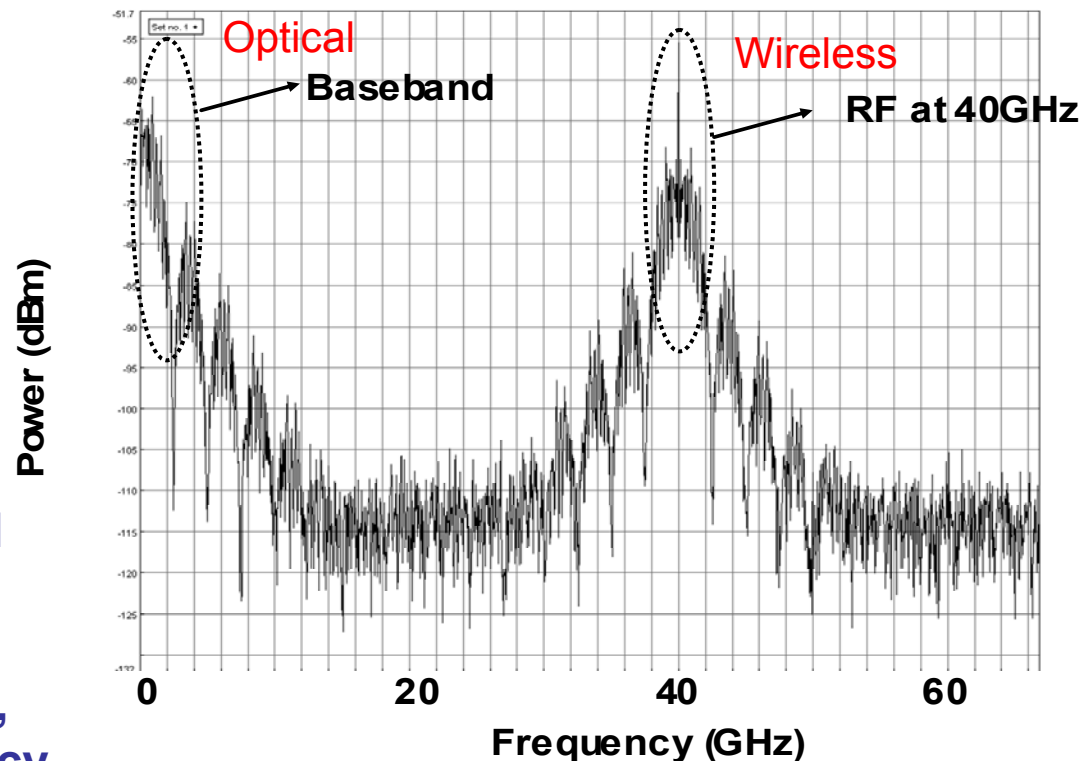

Up-Conversion Based on External Modulation

DSB

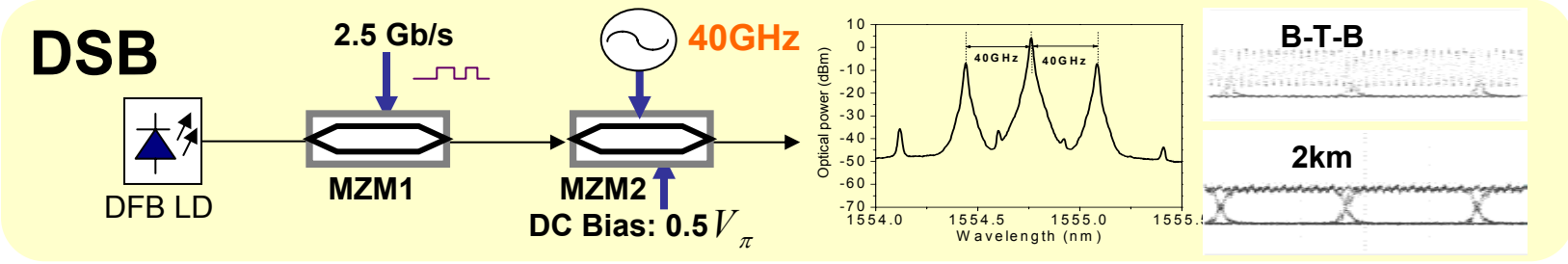

A DFB LD is connected to an MZM1 modulator driven by a 2.5 Gb/s signal. The output of MZM1 goes to a second MZM2 modulator driven by a 40 GHz carrier and a DC bias of $0.5V_{\pi}$. The resulting optical spectrum shows two sidebands separated by 40 GHz. The B-T-B plot shows a clean signal after 2 km of transmission.

SSB

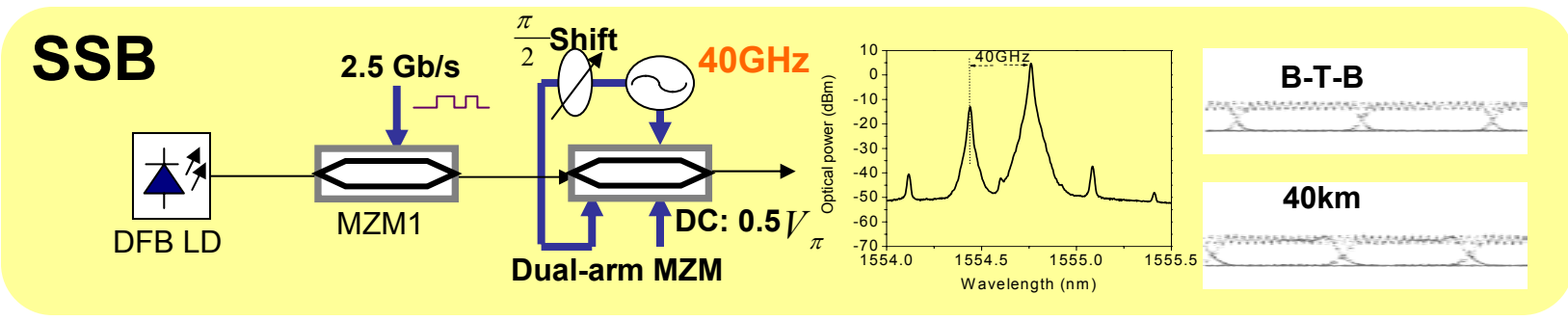

A DFB LD is connected to an MZM1 modulator driven by a 2.5 Gb/s signal. The output of MZM1 goes to a Dual-arm MZM modulator driven by a 40 GHz carrier and a DC bias of $0.5V_{\pi}$. A $\pi/2$ phase shifter is used to suppress one sideband. The resulting optical spectrum shows a single sideband. The B-T-B plot shows a clean signal after 40 km of transmission.

OCS

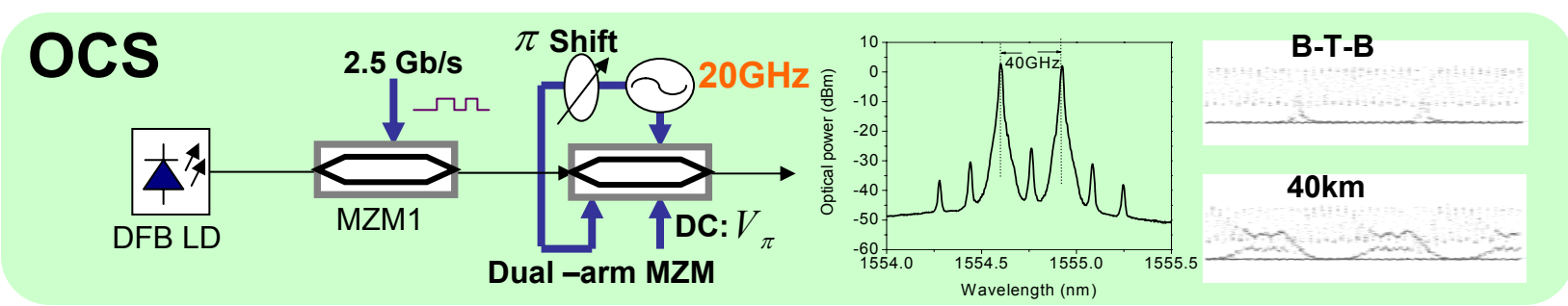

A DFB LD is connected to an MZM1 modulator driven by a 2.5 Gb/s signal. The output of MZM1 goes to a Dual-arm MZM modulator driven by a 20 GHz carrier and a DC bias of V_{π} . A π phase shifter is used to suppress the optical carrier. The resulting optical spectrum shows a suppressed carrier and two sidebands. The B-T-B plot shows a clean signal after 40 km of transmission.

DSB: Double sideband; SSB: Single sideband; OCS: Optical carrier suppression

32-Channel DWDM ROF Transmission based on OCS external modulation

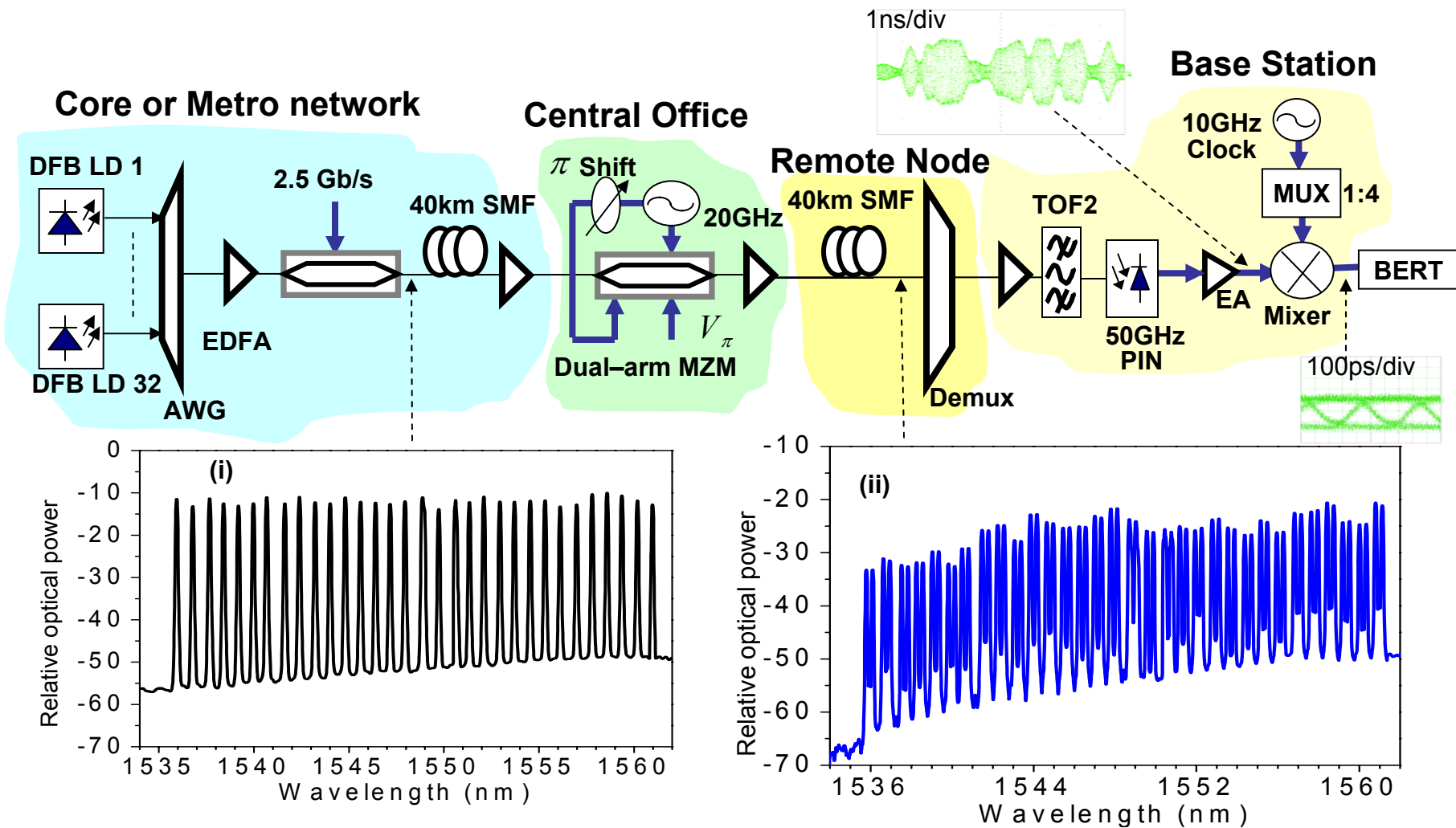

Transmission of 32-Channel ROF Signals

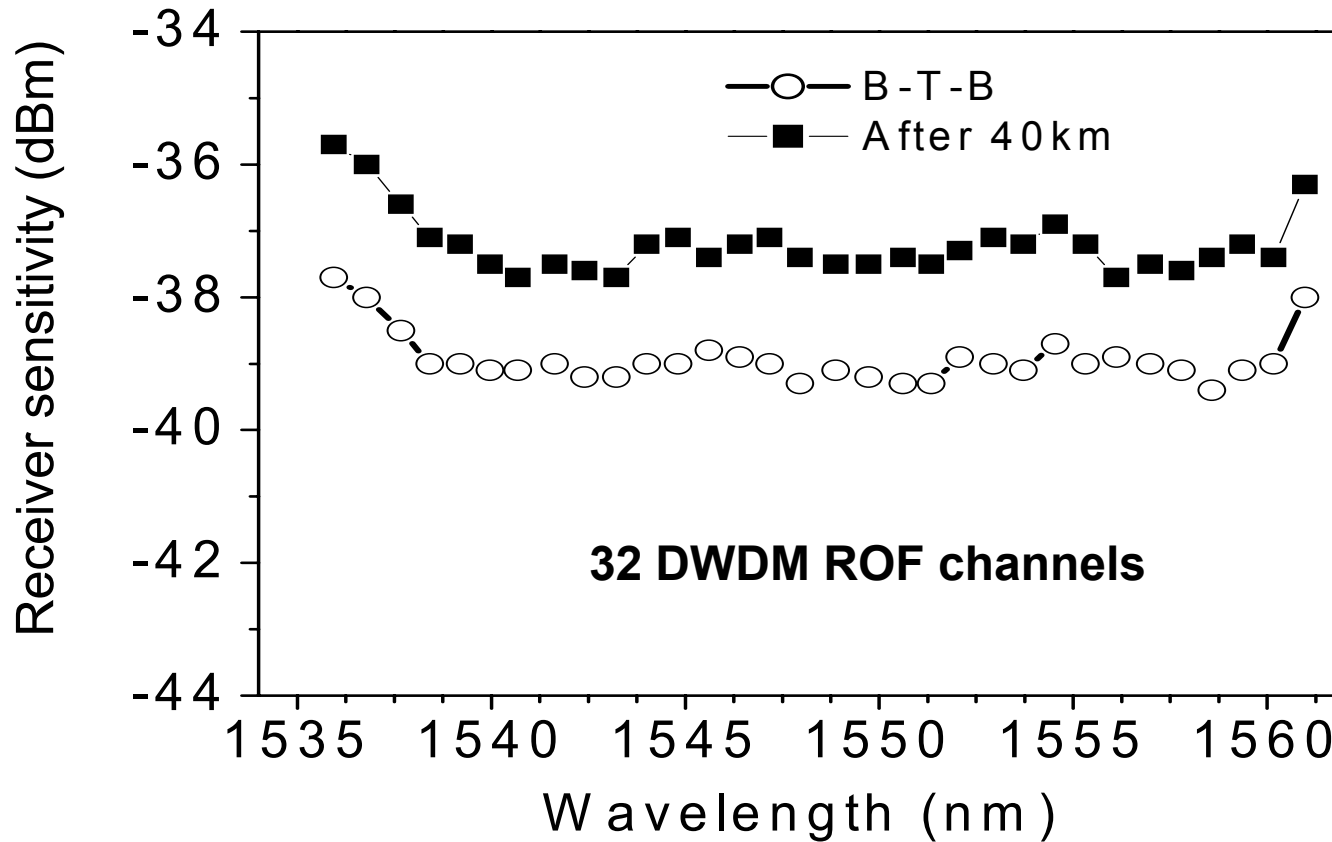

**Power penalty is less 2dB
for all channels.**

J. Yu, Z. Jia and G. K. Chang, ECOC 2005, Post Deadline, 2005, Th 4.5.4.

Key Technologies for RoF Signal Generation

Multiple Bands RF Signal Generation: Microwave and Millimeter-Wave

Multiple RF Signal Generation

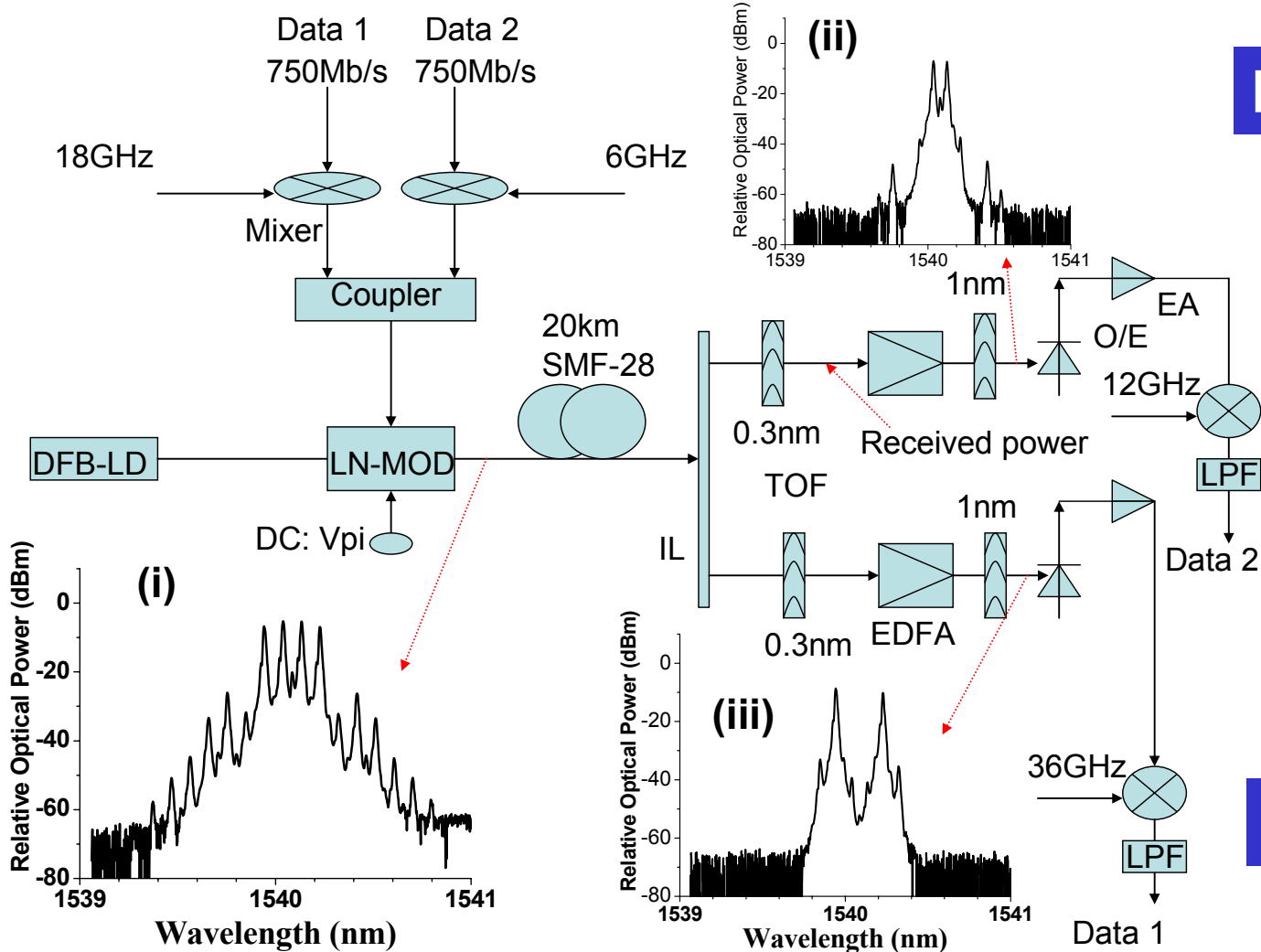

Microwave

mm-wave

Full-Duplex Operation Based on Wavelength Reuse for Upstream

Full-Duplex Colorless Transmission for Uplink

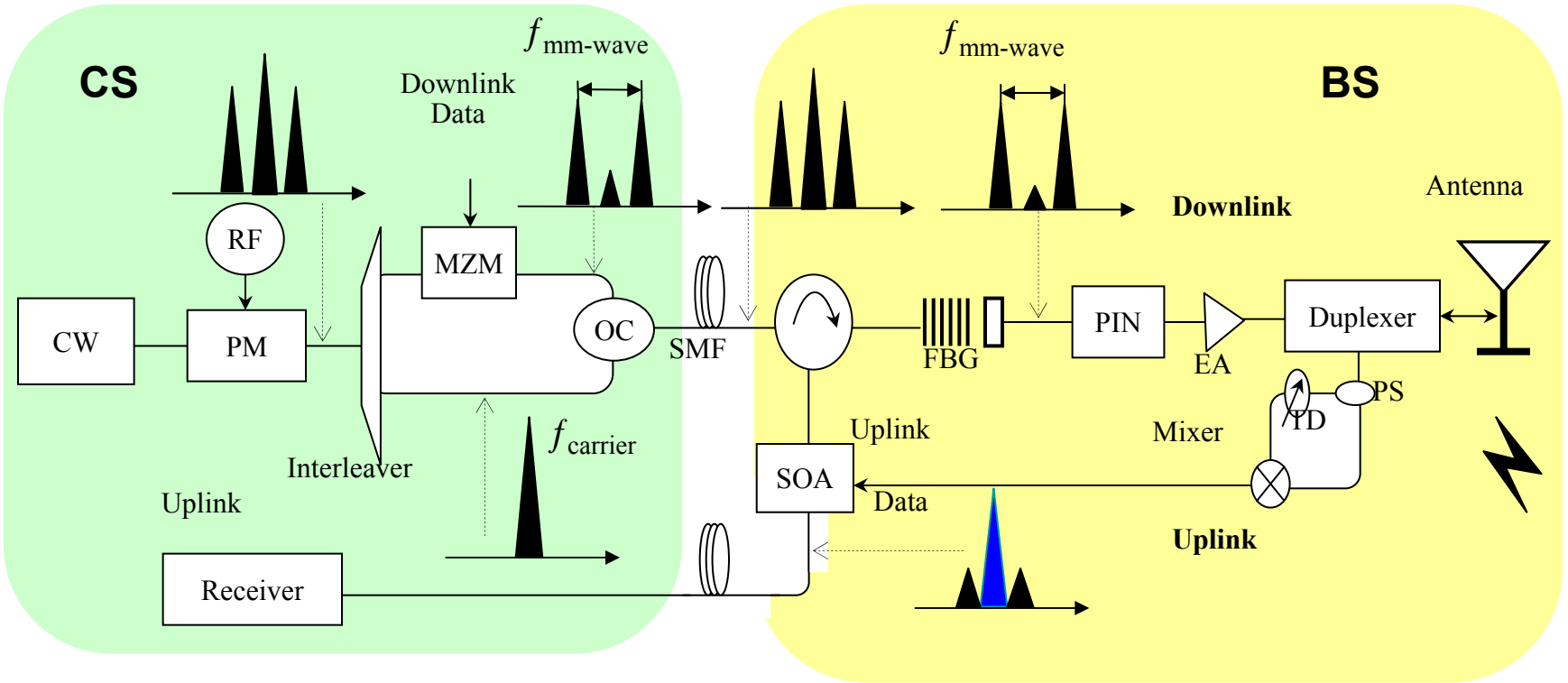

- ✎ At CS, Phase modulation and the subsequent interleaver for optical mm-wave generation.
- ✎ At BS, FBG is used to reflect the optical carrier while pass the downlink mm-wave signal.
- ✎ At BS, SOA performs the function of both amplification and modulation.

Multi-Standards Wireless Transmission

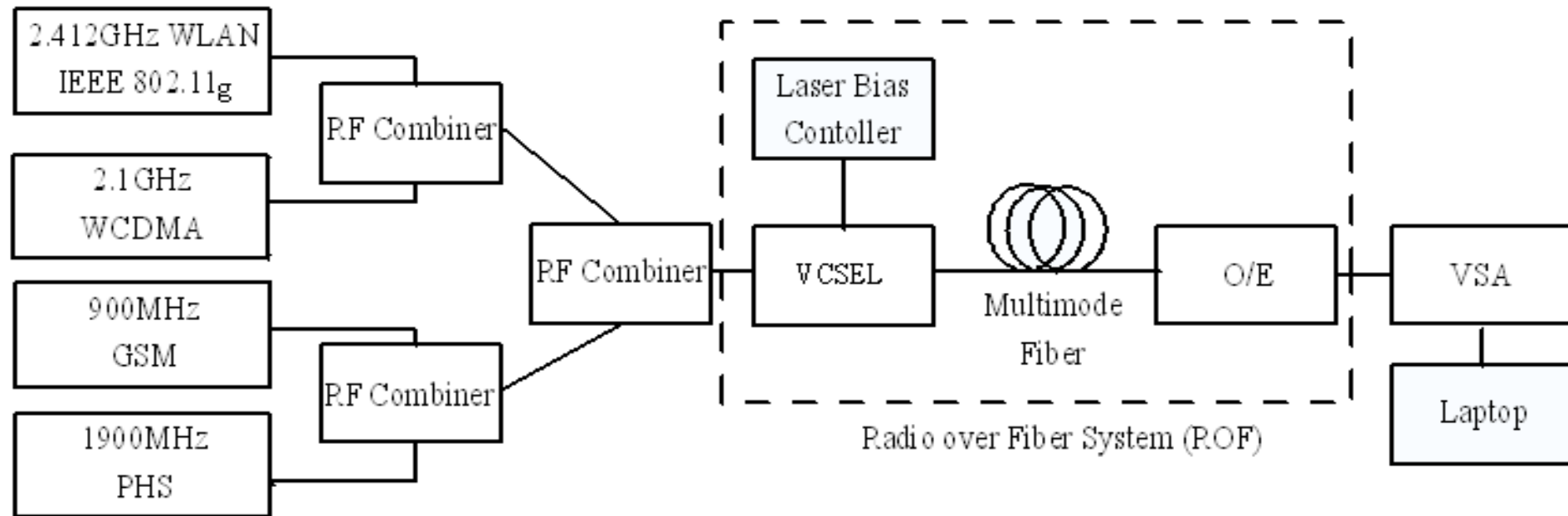

- Various wireless services can share common fiber infrastructure.
- A testbed setup consisting of four wireless standards were simultaneously transmitted to stress the ROF distribution network.
- 802.11g, WCDMA, GSM and PHS were combined electrically and distributed via 300m of MMF ROF system.

What's Next?

Wireless over fiber systems using ROF technologies operating in the 0.8-2.5GHz band have been demonstrated

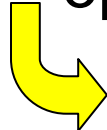
- 
- Moving from RF and microwave to mm-wave carriers for high bandwidth services
 - Moving from point-to-point links to point to multiple points network architectures
 - Moving from low mobility wireless over fiber systems to high speed moving trains and planes
 - Howl's Moving Castle?
 - Facilitating new system architecture and new applications

- **Optical technology**
 - Improve efficiency, simplicity and stability of signal generation and up-conversion for the optical wireless systems;
 - Increase the wavelength utilization efficiency in full-duplex operation when integration with WDM PON;
 - Mitigating the optical mm-wave signals transmission impairment, particularly for the dispersion tolerance.

Future Considerations and Challenges (2)

- **Electrical components and interfaces**

- Low profile, high gain, high frequency antenna and mixer design;
- 40GHz, 60GHz and beyond optical millimeter carrier wave characteristics;
- Improvement for wireless signals synchronization, interference and stability.

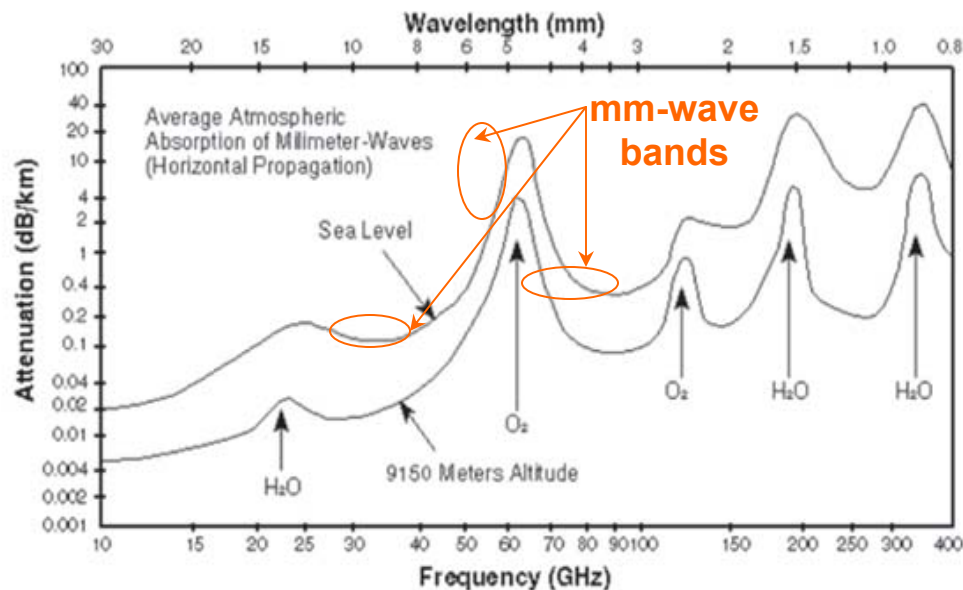

- **O/E and E/O Interfaces**

- Requirement for power, noise, bandwidth and coding methods;
- **Standardization issues.**

Conclusions

- **Optical wireless signal generation and up-conversion techniques play key roles in realizing RoF network.**
- **A novel architecture is developed for bidirectional wireless and optical access network integrated with WDM-PON with wavelength reuse in base stations.**
 - Demo of uncompressed HDTV over both wireline and wireless links
- **Technology challenges are ahead of us:**
 - low-cost optical and RF components,
 - optical wireless system interface,
 - optical wireless protocols, and standardization.