

Next Generation PON System -Access Platforms Integration-

Feb. 25, 2008

Akio Tajima

System Platforms Research Labs,
NEC Corporation

Outline

1. Optical Access Technology and market
2. Next Generation Access (NGA)
 1. Requirements for NGA
 2. NGA Standardization Status
 - Topics, Direction, Status, Feature
3. R&D activities in NEC group
 1. Key optical devices for NGA (10G, WDM)
 2. WDM Access Transport System
 3. OWI Protection
4. Summary

Optical Access Technology Evolution

- Optical access technology enables HDTV distribution to home.
- Higher bandwidth/capacity more than Giga PON technologies make it possible to come in new attractive services.

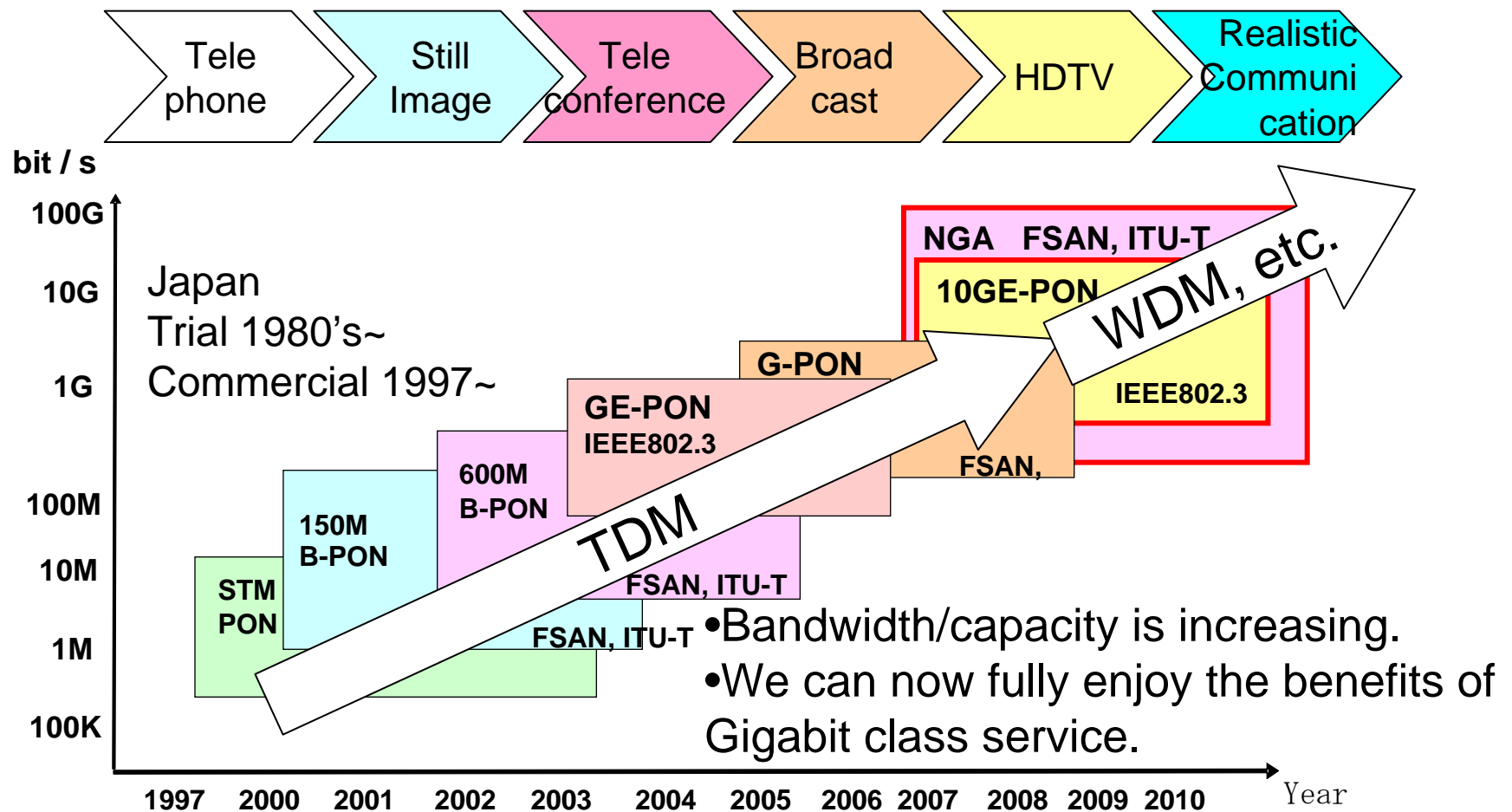

Broadband Subscribers in Japan

Source: Ministry of Internal Affairs and Communication of Japan and Yano Research Institute, Ltd. November 2007

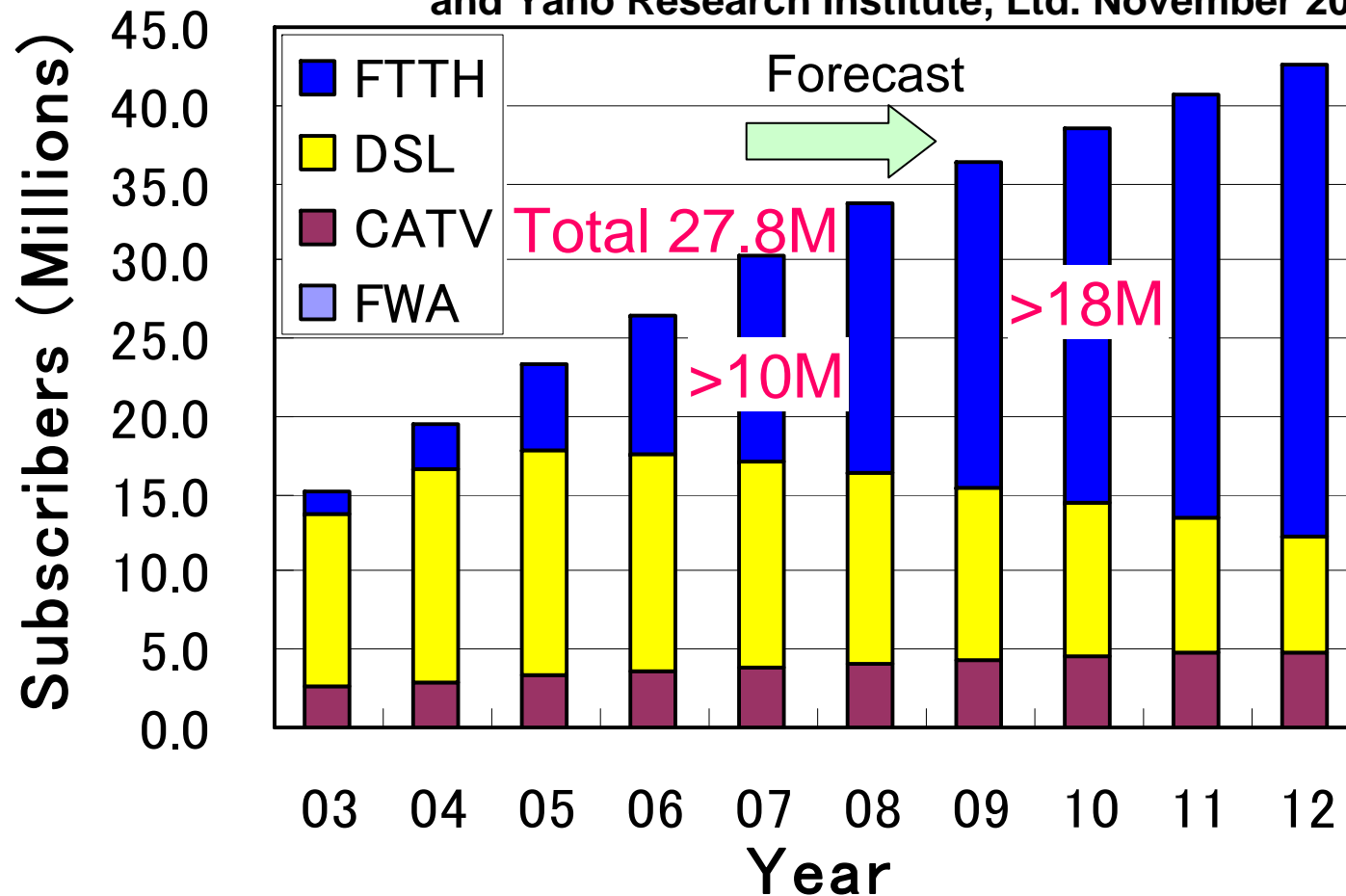

- Broadband subscriber is steadily increasing.
- FTTH subscriptions surpass 10 Million (Sept. 2007)
- Meanwhile, DSL subscriptions declined.

Current Optical Access Architecture

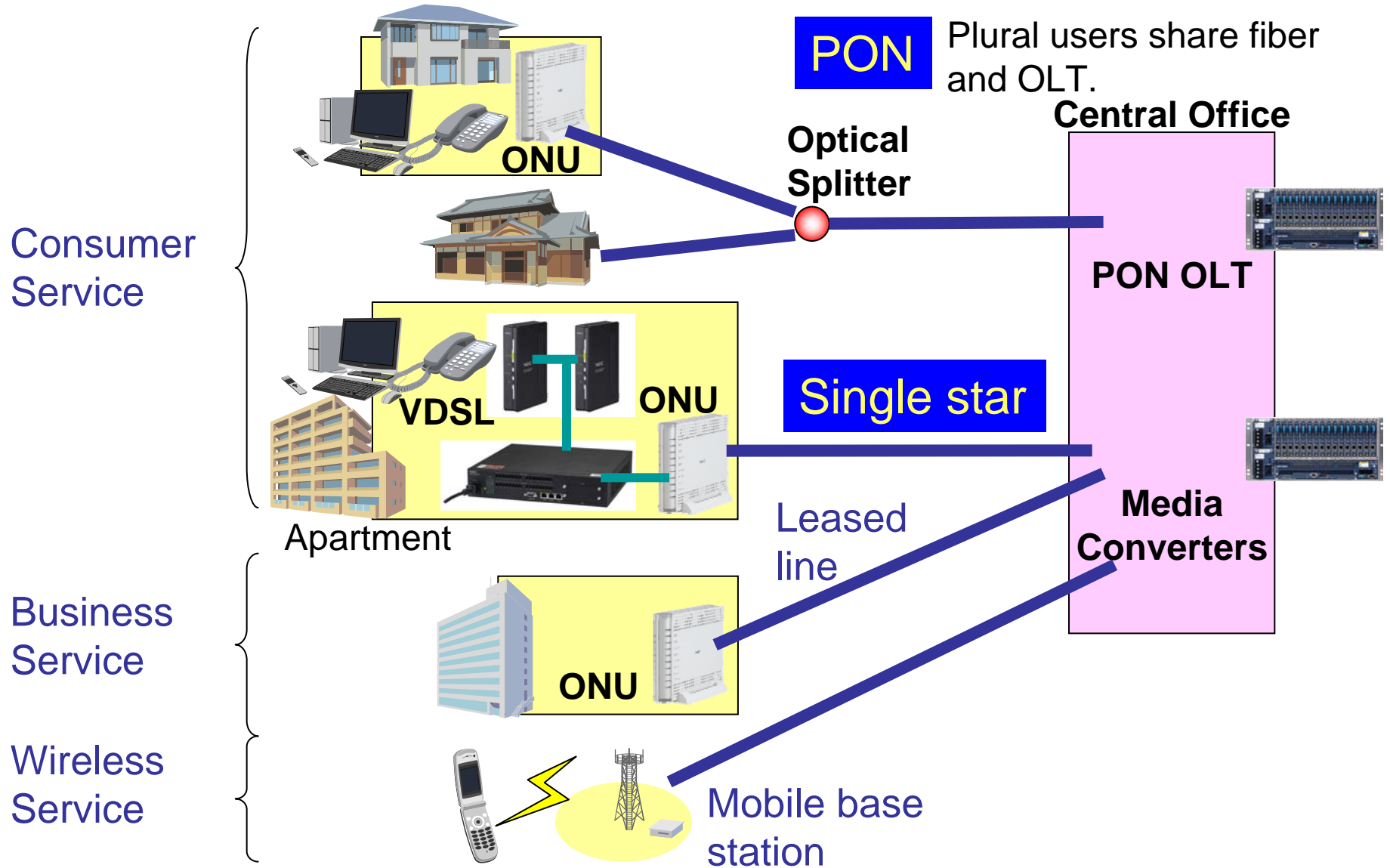

Outline

1. Optical Access Technology and market
2. Next Generation Access
 1. Requirements for NGA
 2. NGA Standardization Status
 - Topics, Direction, Status, Feature
3. R&D activities in NEC group
 1. Key optical devices for NGA (10G, WDM)
 2. WDM Access Transport System
 3. OWI Protection System
4. Summary

Requirements and Key Technologies for NGA

Requirements

- Higher bandwidth/capacity than current system
- Coexistence with installed system
- Maximum utilization of installed Optical Distribution Network (ODN).
- Limited floor in CO
- Limited power supply in CO
- Wider coverage area
- Fixed and wireless integration
- Higher Reliability
- Security

Key Technologies

- TDM (e.g. 10Gbps/ λ)
- WDM (e.g. colorless ONU)
- Dual-rate Burst Receiver
- High-power optical transmitter and high-sensitivity optical receiver for higher-speed (10Gbps) transmission.
- FEC
- Integrated access platforms (10GE-PON system)
- WDM repeater
- FTTx/Wireless Integration
- FTTx/WiMAX Protection
- Cryptosystem (e.g. QKD)

IP-TV Service Trend

Require *much* more bandwidth

Service Offerings	
Today	Near Future (2010)
<ul style="list-style-type: none"> • Broadcast • Video-on-Demand 	<ul style="list-style-type: none"> • Time-shifted / narrowcast • All-channel personal video recorder • Picture-in-picture / split screen • Digital cinema distribution • Personal multimedia publishing • Residential and business digital video surveillance

Bandwidth per Channel	
Today	Near Future (2010)
<ul style="list-style-type: none"> • Standard Definition TV (SDTV) <ul style="list-style-type: none"> • 2 Mbps per channel 	<ul style="list-style-type: none"> • High-Definition TV (HDTV) <ul style="list-style-type: none"> • ~10 Mbps per channel • Large Screen Digital Imagery (LSDI) <ul style="list-style-type: none"> • Standardized by ITU-T J.601 • 40 to 160 Mbps per channel

Number of Channels	
Today	Near Future (2010)
<ul style="list-style-type: none"> • 30 ~ 100 channels 	<ul style="list-style-type: none"> • 1000 or more channels <ul style="list-style-type: none"> • Mix of SDTV, HDTV, LSDI

Forecast of US Households Using HDTV

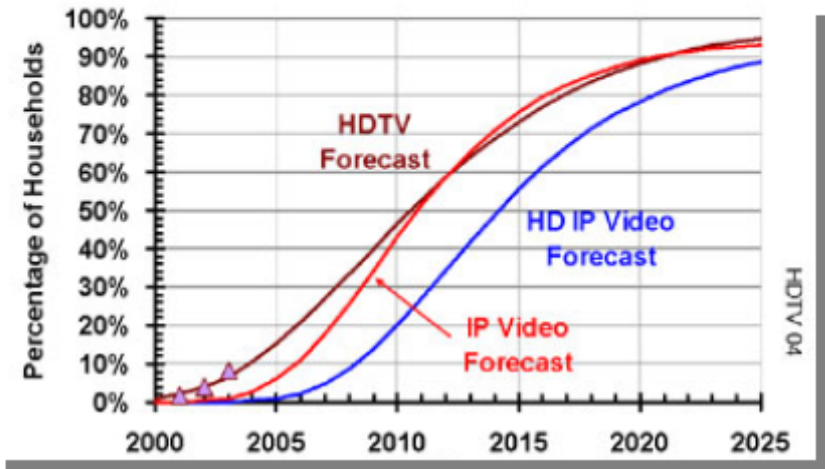

Reproduced with permission from Technology Futures, Inc.

For now, AT&T will offer 200 channels, though it expects to offer 1,000 or more channels when it expands the service to other markets in about six months. Its channel lineup already includes major networks as well as ESPN, HBO, the Discovery Channel, the Disney Channel, MTV, the History Channel, USA, CNN, National Geographic and others.

The Wall Street Journal
January 5, 2006

Source: http://www.ieee802.org/3/cfi/0306_1/cfi_0306_1.pdf

Maximum utilization of installed ODN

Coexistence with current system

1. Compatible fiber plant with current system
 - Fiber plant which is constructed for current system, must be used for NGA.
 - G. 652 SMF
 - Power budget (30 dB and penalty < 1 dB, or 29 dB without penalty)
 - 20km reach
 - More than 32 split ratio
2. Coexistence with current system.
 - NGA must avoid to interfere with existing current system in a same fiber.
 - Optical overlay of RF video must be also

supported
Source: http://www.ieee802.org/3/10GEPON_study/public/may06/otaka_1_0506.pdf

Optical Access For Wireless Back-Haul

- 4th Gen mobile communication will be ubiquitous
 - Bandwidth: ~30Mbps/user, 100M~1Gbps/access point
 - Access point coverage will decrease
 - Number of access points will increase
 - PON is a natural back-haul solution for the 4th Gen access points
- Next generation wireless back-haul
 - 802.11n: up to 100 Mbps per device
 - 802.16e: up to 70 Mbps per access point

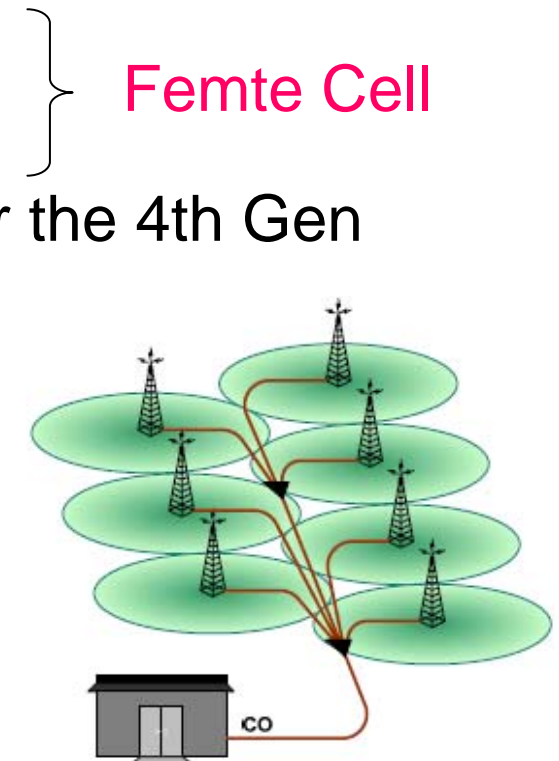

Source: http://www.ieee802.org/3/cfi/0306_1/cfi_0306_1.pdf

Requirements and Key Technologies for NGA

Requirements

- Higher bandwidth/capacity than current system
- Coexistence with installed system
- Maximum utilization of installed Optical Distribution Network (ODN).
- Limited floor in CO
- Limited power supply in CO
- Wider coverage area
- Fixed and wireless integration
- Higher Reliability
- Security

Key Technologies

- TDM (e.g. 10Gbps/ λ)
- WDM (e.g. colorless ONU)
- Dual-rate Burst Receiver
- High-power optical transmitter and high-sensitivity optical receiver for higher-speed (10Gbps) transmission.
- FEC
- Integrated access platforms (10GE-PON system)
- WDM repeater
- FTTx/Wireless Integration
- FTTx/WiMAX Protection
- Cryptosystem (e.g. QKD)

Access Platforms Integration over 10GEPON

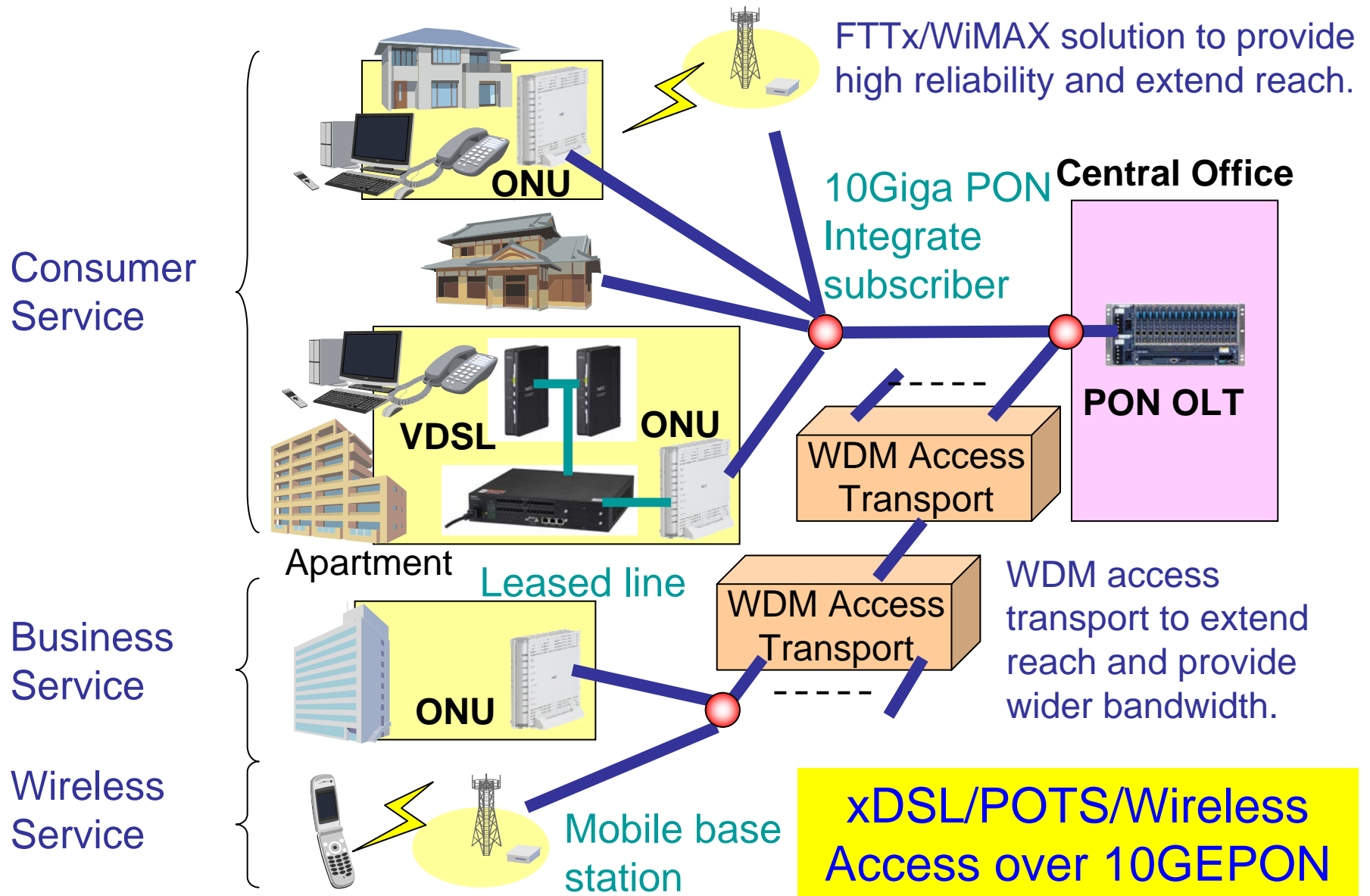

Outline

1. Optical Access Technology and market
2. Next Generation Access
 1. Requirements for NGA
 2. NGA Standardization Status
 - Topics, Direction, Status, Feature
3. R&D activities in NEC group
 1. Key optical devices for NGA (10G, WDM)
 2. WDM Access Transport System
 3. OWI Protection System
4. Summary

Standard Schedule

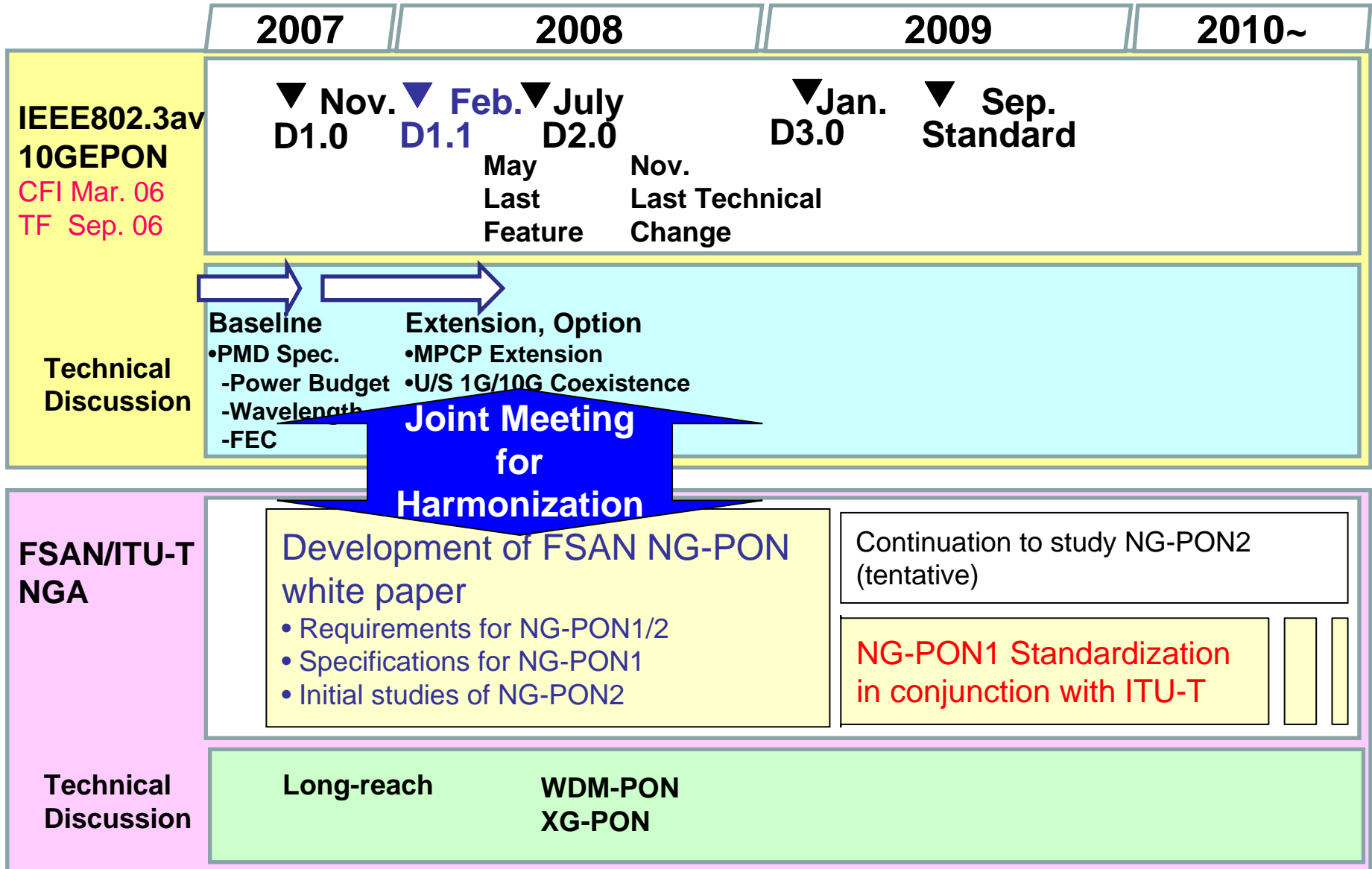

10GEPON –Objectives-

- Support subscriber access networks using point to multipoint topologies on optical fiber
- PHY(s) to have a BER better than or equal to 10^{-12} at the PHY service interface
- Provide physical layer specifications:
 - PHY for PON, 10 Gbps downstream/1 Gbps upstream, single SM fiber
 - PHY for PON, 10 Gbps downstream/10 Gbps upstream, single SM fiber
- Define up to 3 optical power budgets that support split ratios of 1:16 and 1:32 and distances of at least 10 and at least

Table: Power Budget Classes

	1:16	1:32
10km	PR10 , PRX10	PR20 , PRX20
20km	PR20 , PRX20	PR30 , PRX30

PR: 10G/10G
PRX:10G/1G

10GEPON –Features- Coexistence with GEPON, RF-video

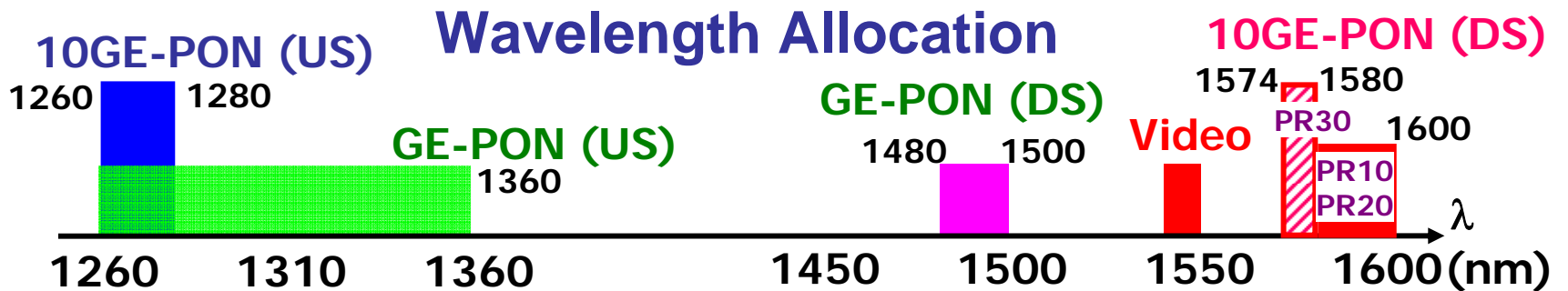
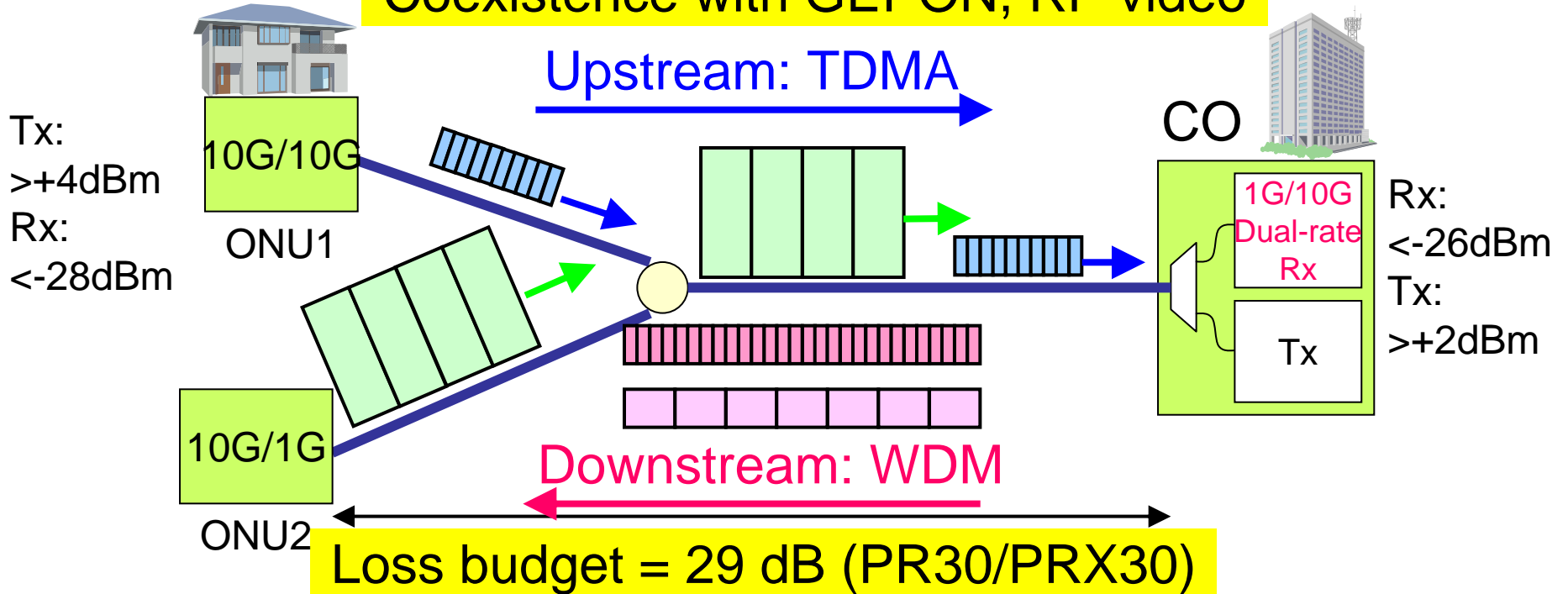

Key Device: High-sensitivity APD, High-Power LD

Outline

1. Optical Access Technology and market
2. Next Generation Access
 1. Requirements for NGA
 2. NGA Standardization Status
 - Topics, Direction, Status, Feature
3. R&D activities in NEC group
 1. Key optical devices for NGA (10G WDM)
 2. WDM Access Transport System
 3. OWI Protection System
4. Summary

Key Device for 10GEPON High-Power Transmitter

1.3um AlGaInAs BH DFB-LD

- AlGaInAs MQW
 - High relaxation oscillation frequency even at high temperature
- BH structure with semi-insulating current blocking layer
 - Reduce parasitic capacitance by Fe doped InP for high-speed (>10GHz) operation

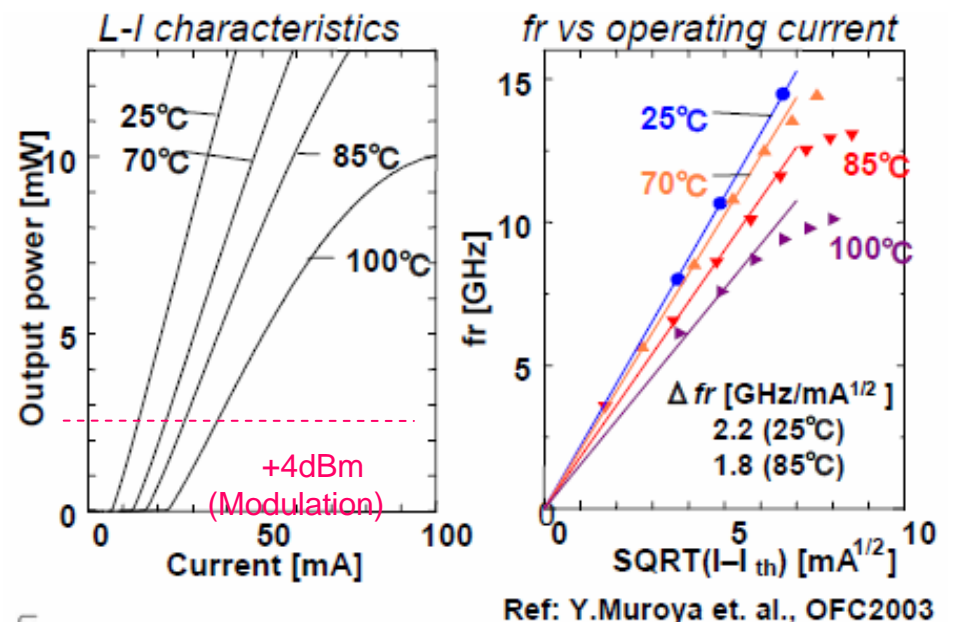
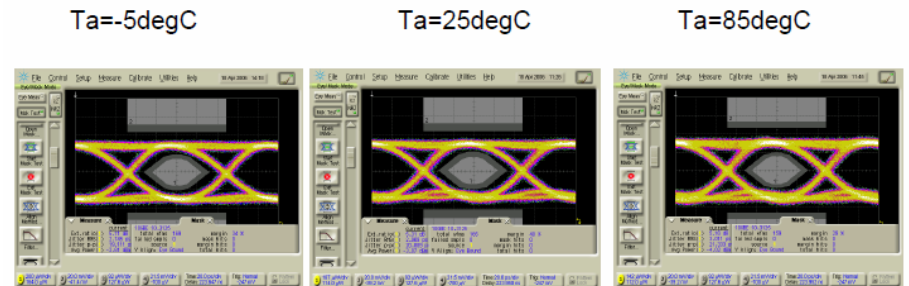
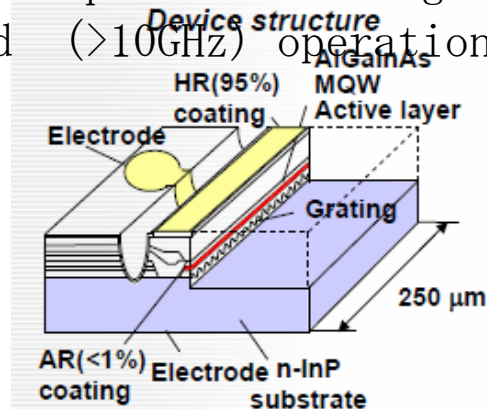

High-power (>+4dBm) 10Gbps operation was confirmed.

Key Device for 10GEPON High-Performance Receiver

- Two type of high-performance APD have developed.
 - Mesa-type APD
 - Simple Mesa structure is suitable for mass production and low cost.
 - Tolerant for high-power.
 - High reliability.
 - Waveguide APD
 - Waveguide structure realizes high quantum efficiency and high sensitivity.
 - WG structure is suitable for surface mounting and PLC.

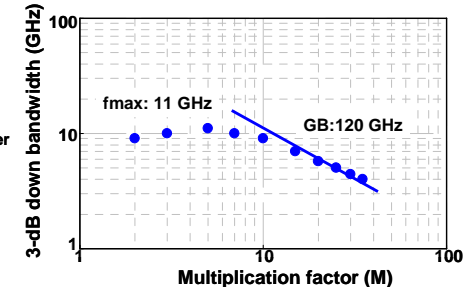
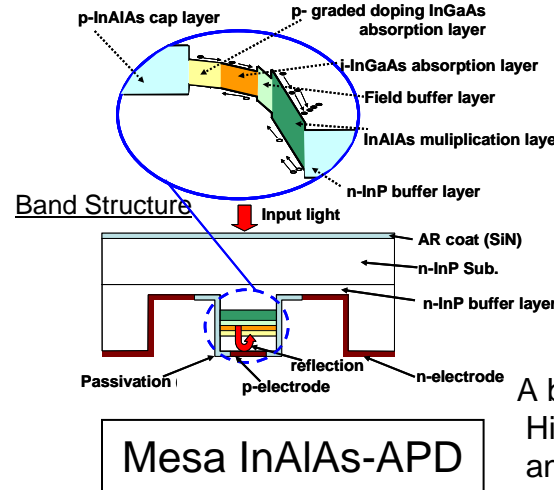

Frequency Response

A back-illuminated mesa APD. High reliability with thin multiplication and two-step absorption layer.

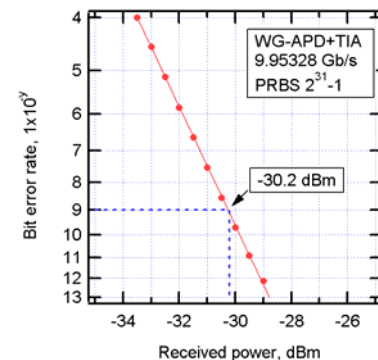
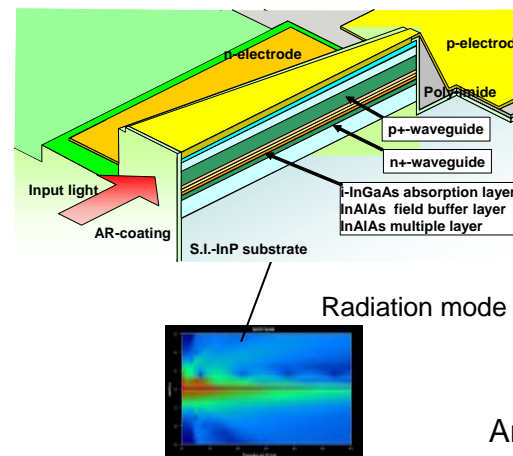

Received Sensitivity

An asymmetric waveguide APD with thin SAM structure. High input power operation with asymmetric structure.

*SAM: Separated absorption and multiplication structure

Colorless ONU Technology for WDM-PON

	Local Emission		Wavelength Supply	
Technique	Tunable	Spectrum Slicing	Loop-back	Wavelength-seeding
ONU configuration				
Modulation	Direct/External	Direct	External	Direct
Rate	10Gbps	1.25Gbps	10Gbps	1.25Gbps
Location of US light source	ONU	ONU	OLT	ONU

TLD: Tunable Laser Diode, BLS: Broadband Light Source, RSOA: Reflective Semiconductor Optical Amplifier

Source: J. Kani et al., "Next Generation Optical Access Networks: Possible Directions and Technical Challenges," ECOC2006, Th2.1.2

Full band Tunable LD

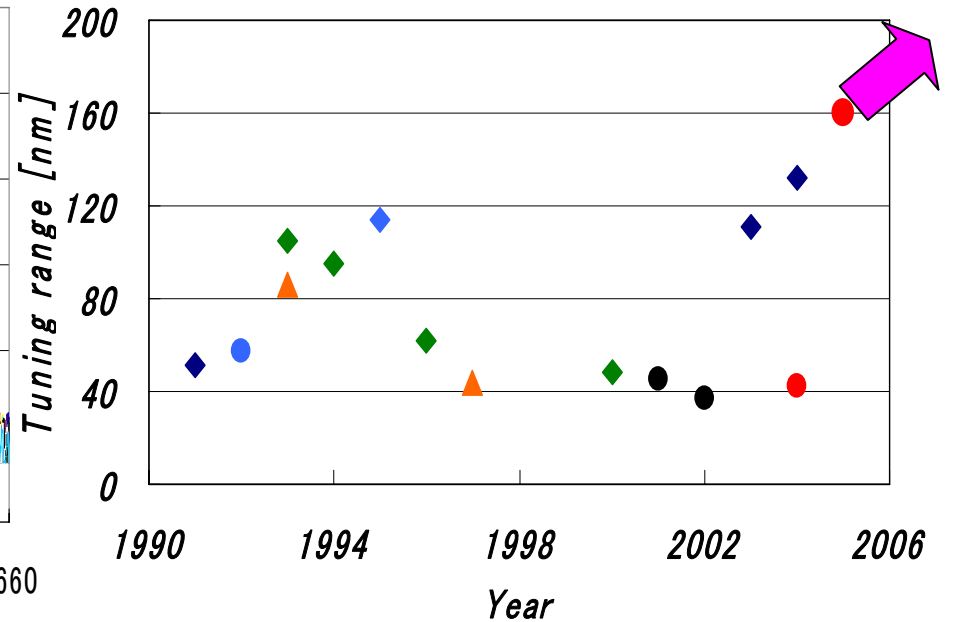
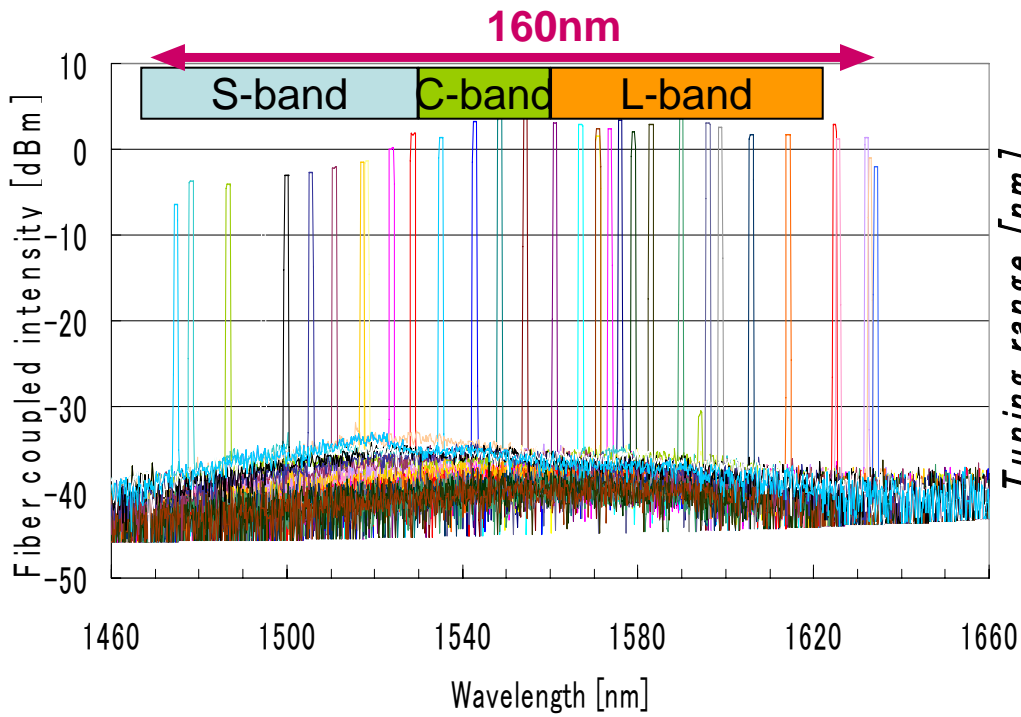
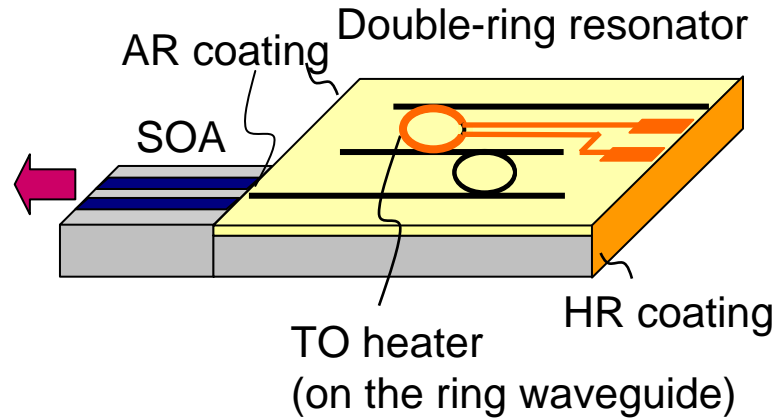

WDM Access Transport System

- WDM access transport to extend reach and provide wider bandwidth
- The system multiplexes burst optical signal and behaves as a repeater as well.
 - Effective use of access network fiber by reducing number of fibers
 - Extend optical reach beyond 20km with using repeaters to 60km
 - Compatible in mixed deployment with PON, point-to-point or other systems

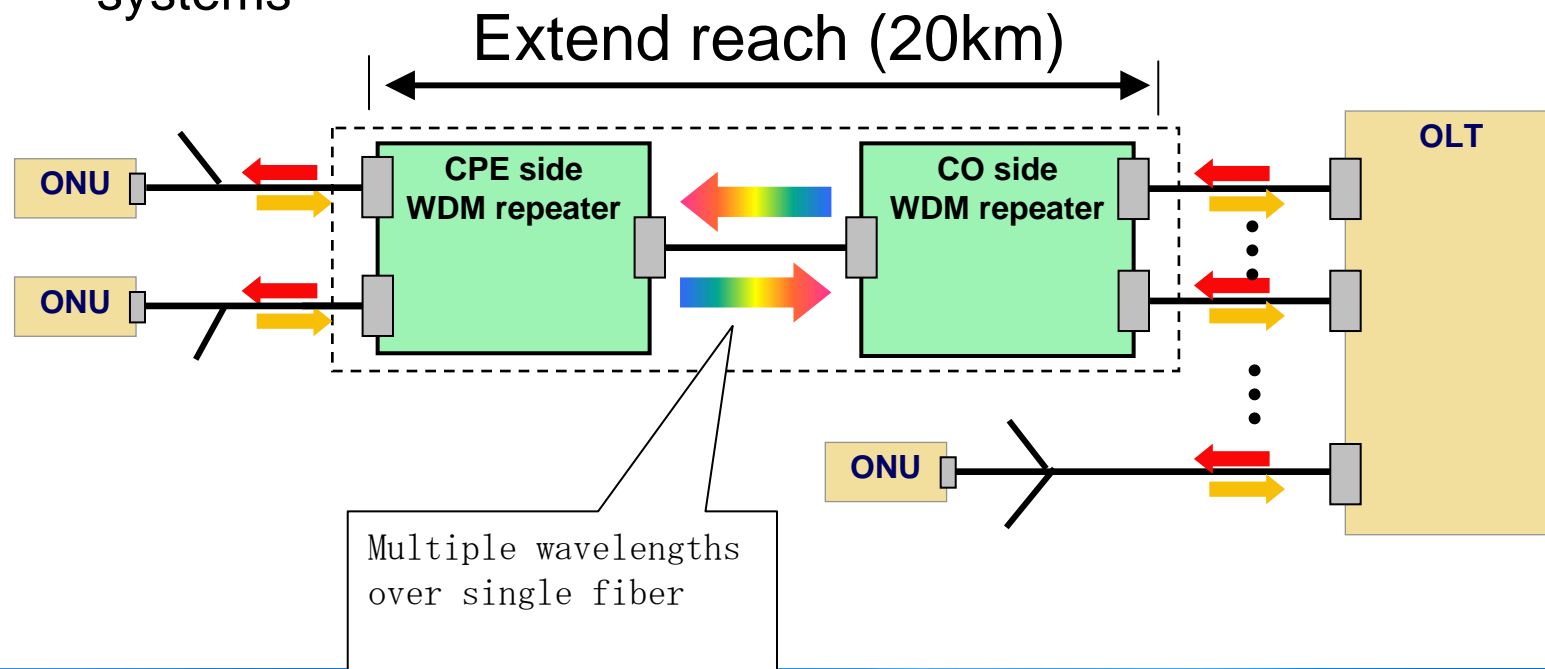

FTTx/ WiMAX Protection

- Optical access will become social infrastructure
- High reliability, at the same time low-cost is indispensable

Existing technology

Without integrated FTTH/Wireless redundant system

- Requires external switch fabric for protection switching
- Requires explicit addressing management for redundant path, SDH like protection scheme is preferable to implicit redundant path management

Can not provide flexible redundant system.

Our solution

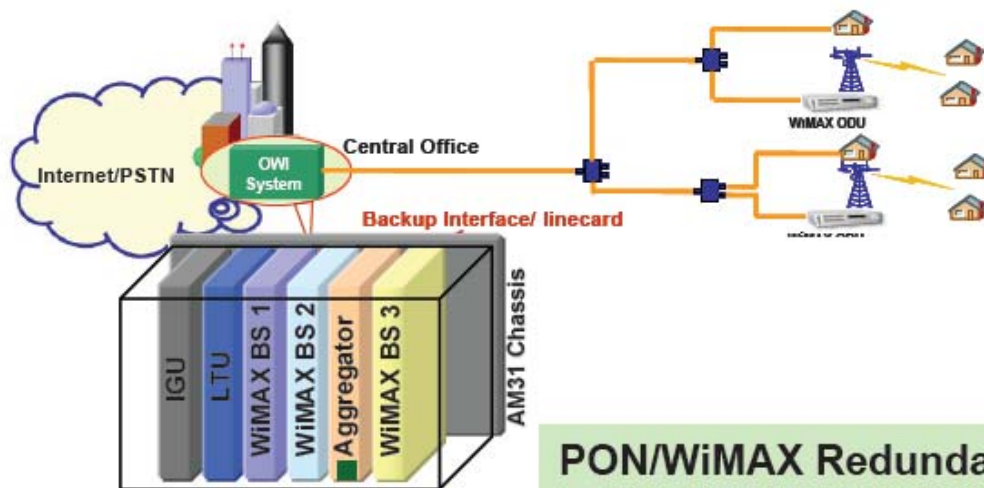

WIMAX N+1 Protection by aggregator

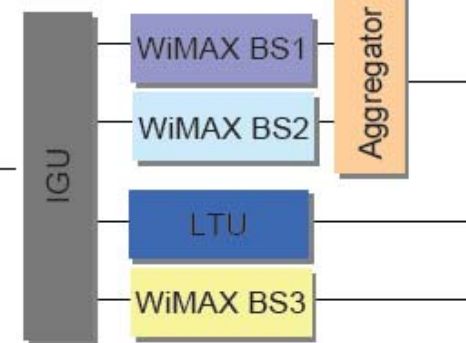

PON/WiMAX protection by IGU

PON/WiMAX Redundancy

- Realizes PON/WiMAX line card protection
- Switching will be done by IGU (Integrated Gateway unit)

Summary

- Requirements and trends for next generation optical access technologies are presented.
 1. Requirements for NGA
 2. NGA Standardization Status
- R&D activities in NEC are introduced.
 1. Key optical devices for NGA
 2. WDM Access Transport System
 3. OWI Protection System
- I believe that these technologies lead to realizing 10GEPON-based integrated optical access.

For “Next” Next Generation Access

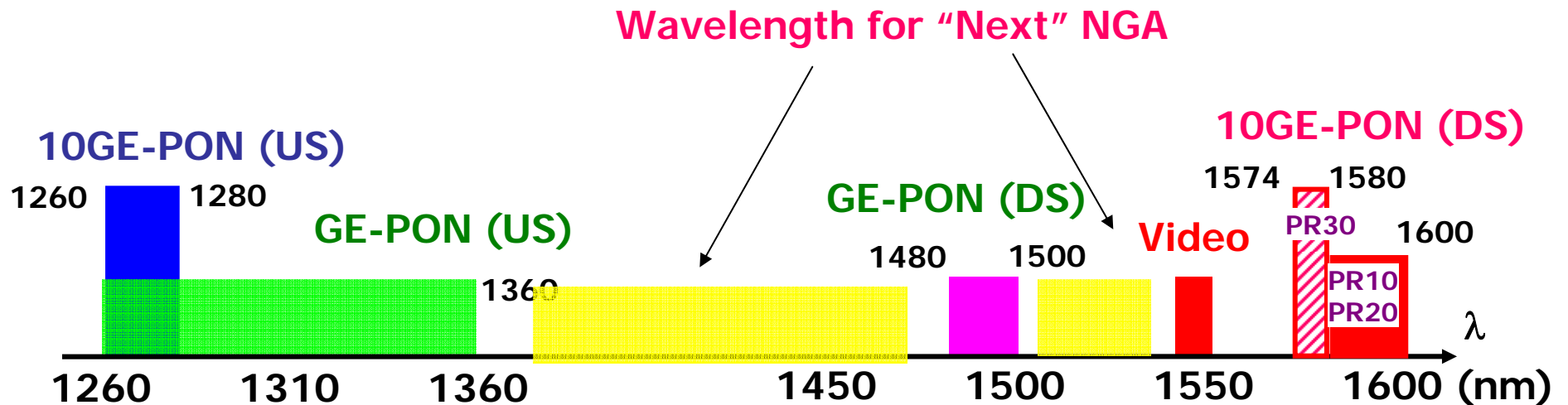

- New technologies (e.g. OFDM, OCDM) are expected for realizing more higher bandwidth and flexibility.
- However, it is difficult to remove legacy system
- Coexistence architecture with legacy system is desired
- Coexistence technology will be technical issues.

For Higher Capacity

- In order to enlarge bandwidth/capacity, we have options, WDM, TDM and etc.
- Now 10Gbit/s continuous transmission technology is mature, e.g. 10Gigabit Ethernet.
- TDM, especially 10Gbit/s PON technologies will be available around 2010.

1st step: 10Gbit/s PON

2nd step: WDM PON

