

Optical Wireless Convergence

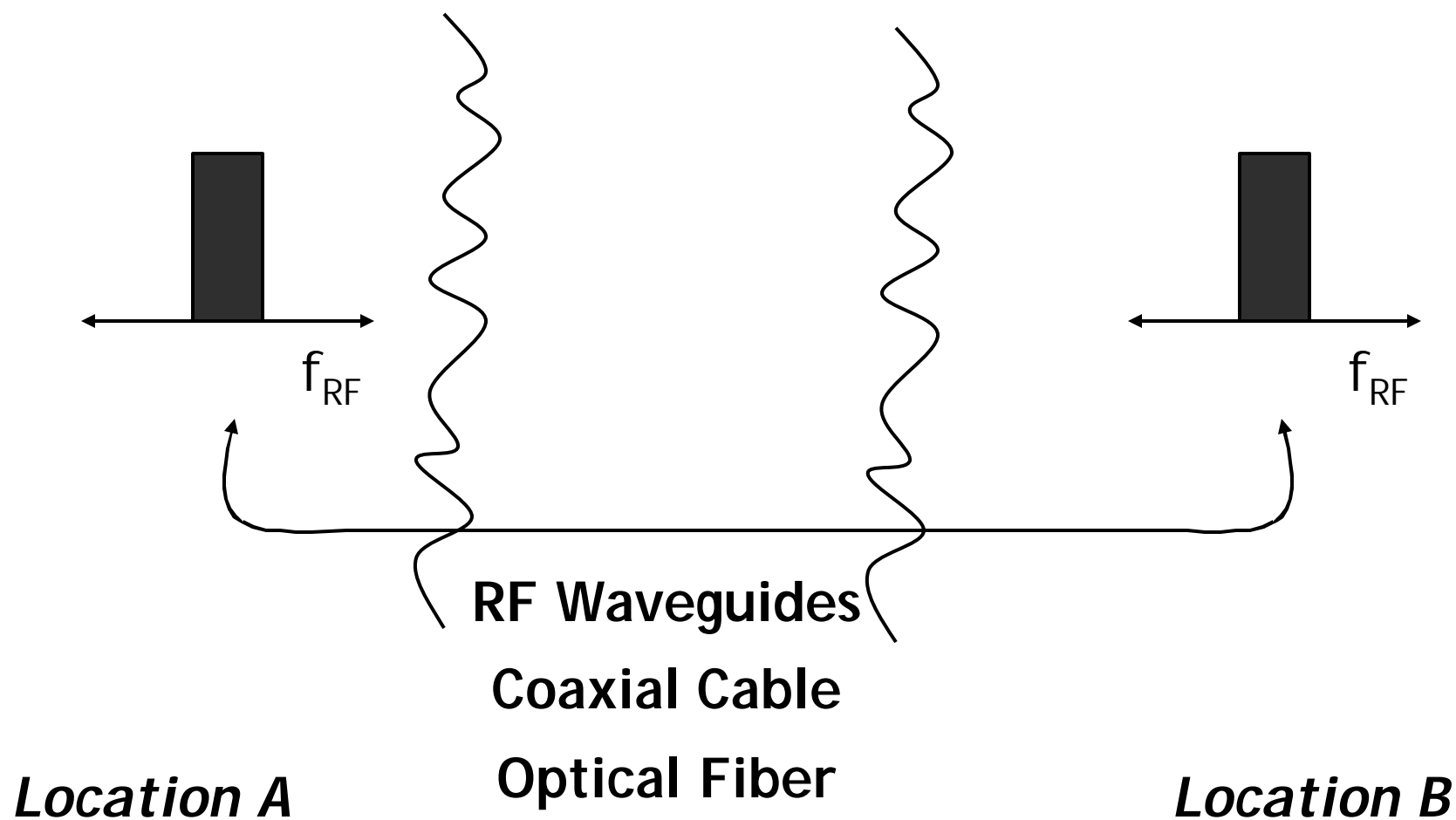

Tod Sizer, Director
Broadband and Wireless Access Network Research
Bell Laboratories
ts2@alcatel-lucent.com

A Challenge



A Challenge [2]

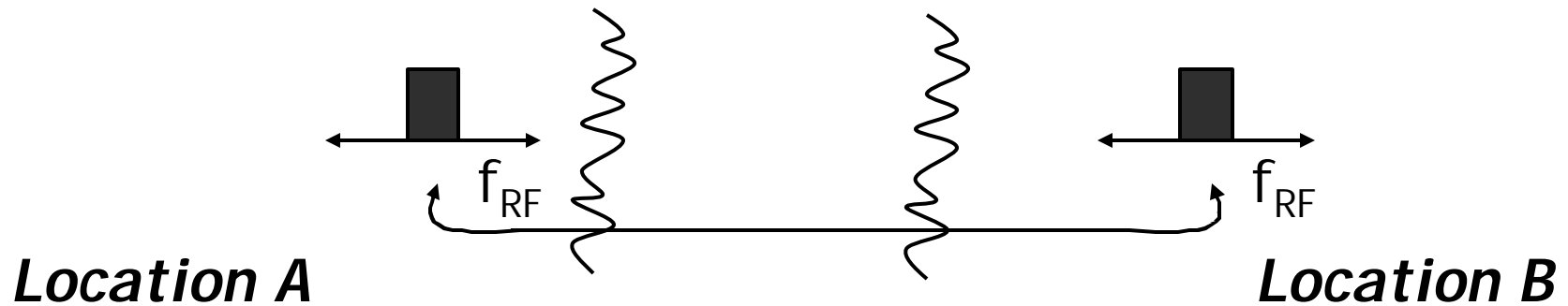

RF Waveguides

Coaxial Cable

Optical Fiber

All - point to point technologies

Largely proprietary (unique) format for transmission

Unique end point devices → higher costs

A Challenge [3] Our approach

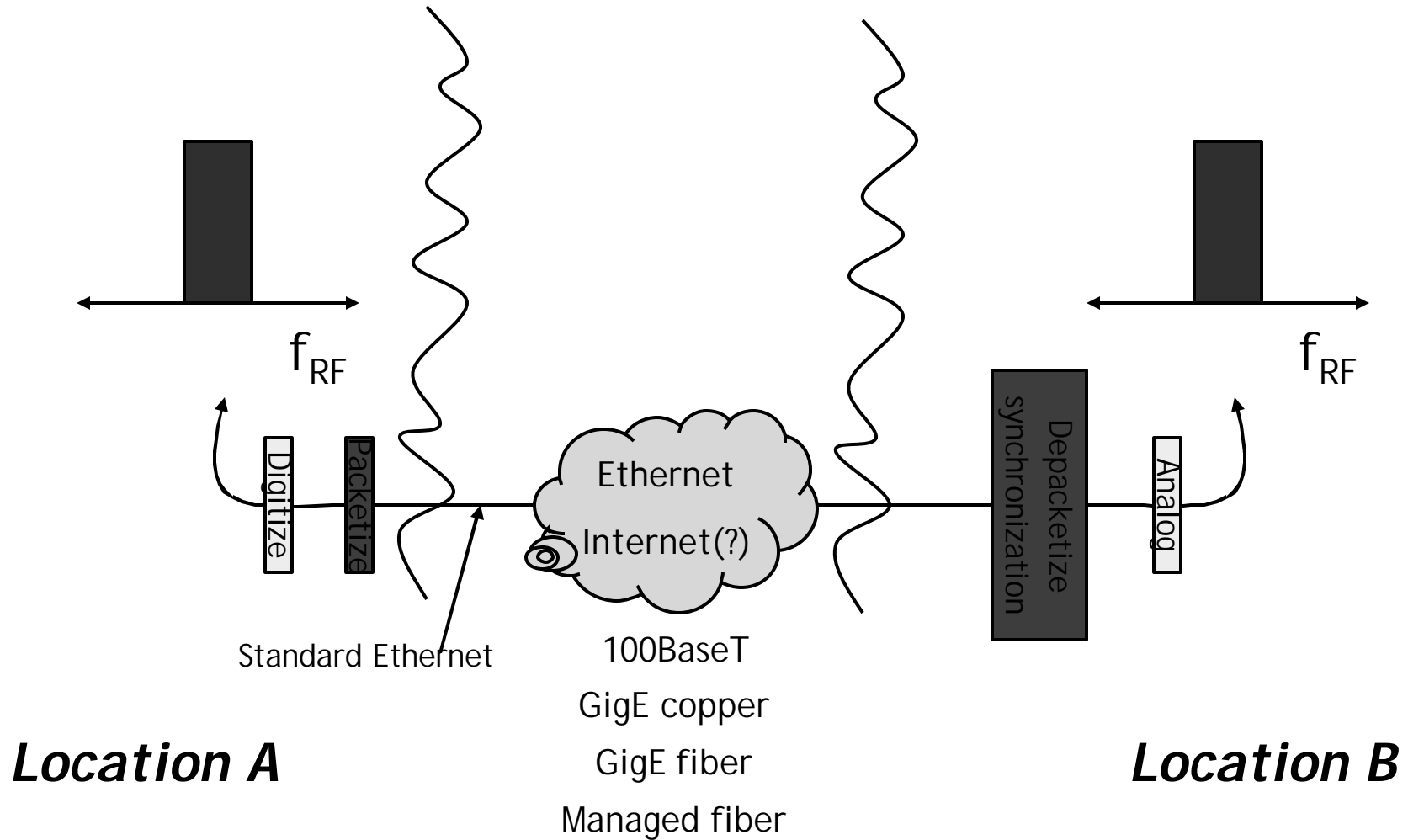

Radio Digitizing Technique

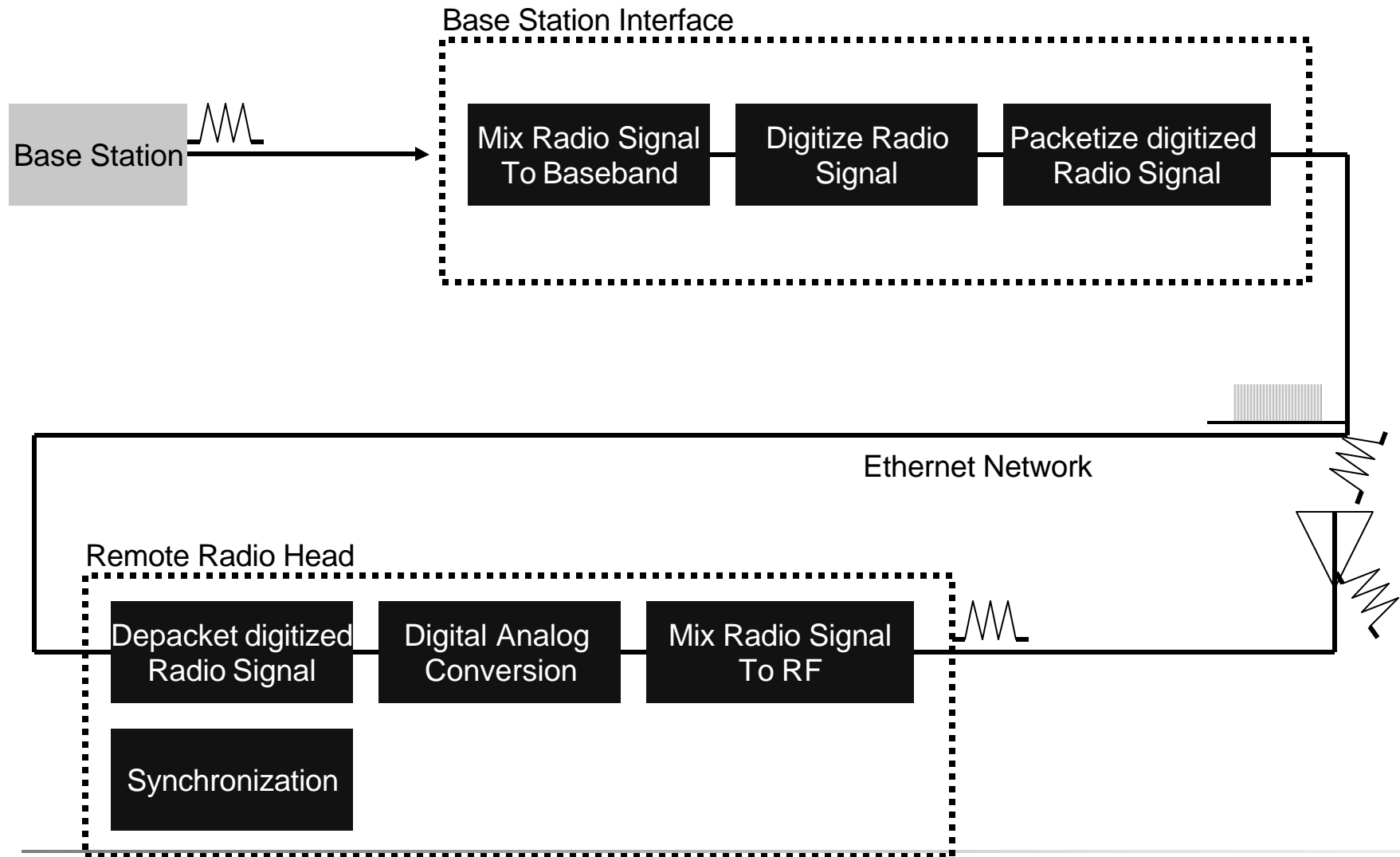

Cellular Signal Distribution Scheme

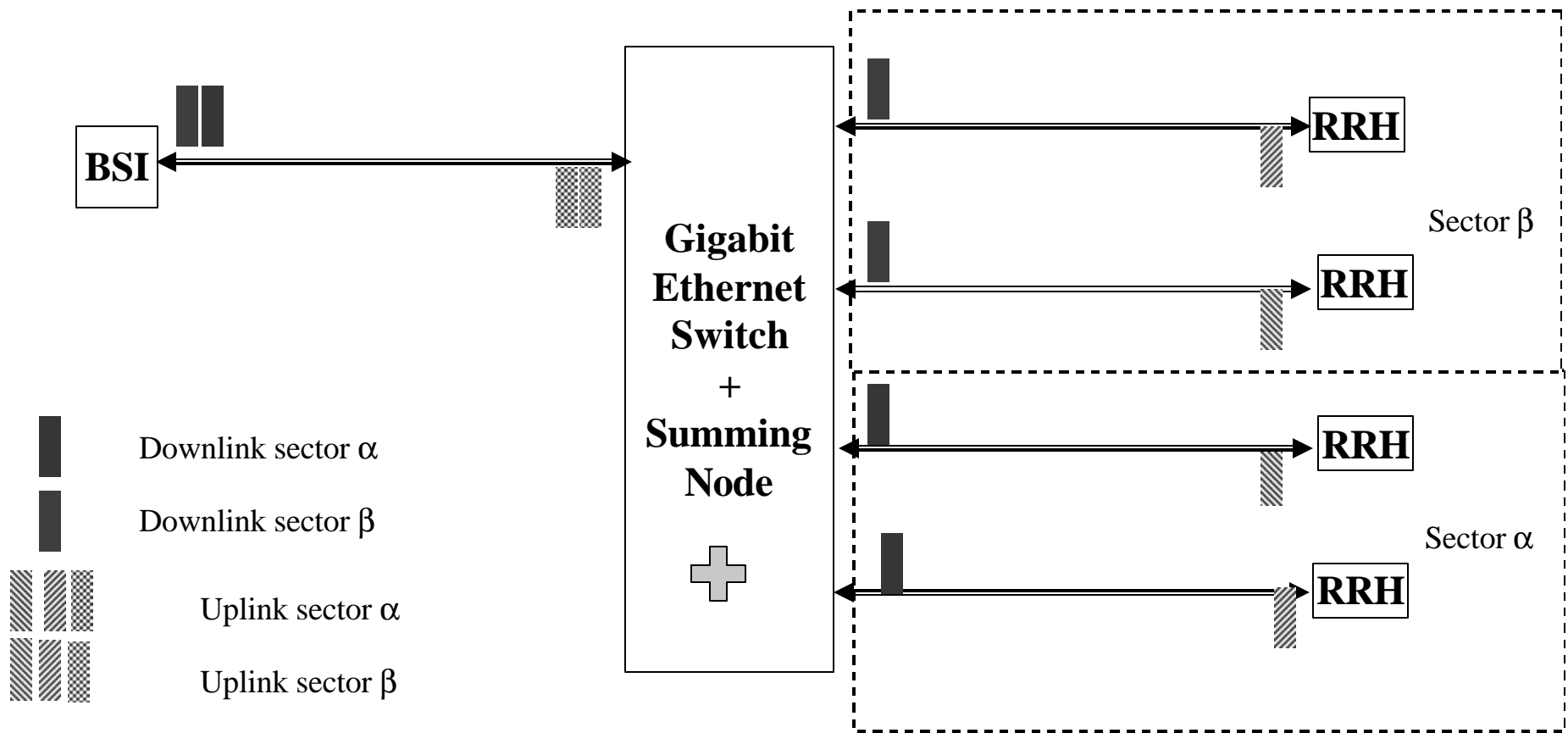

Cellular Signal Distribution Scheme

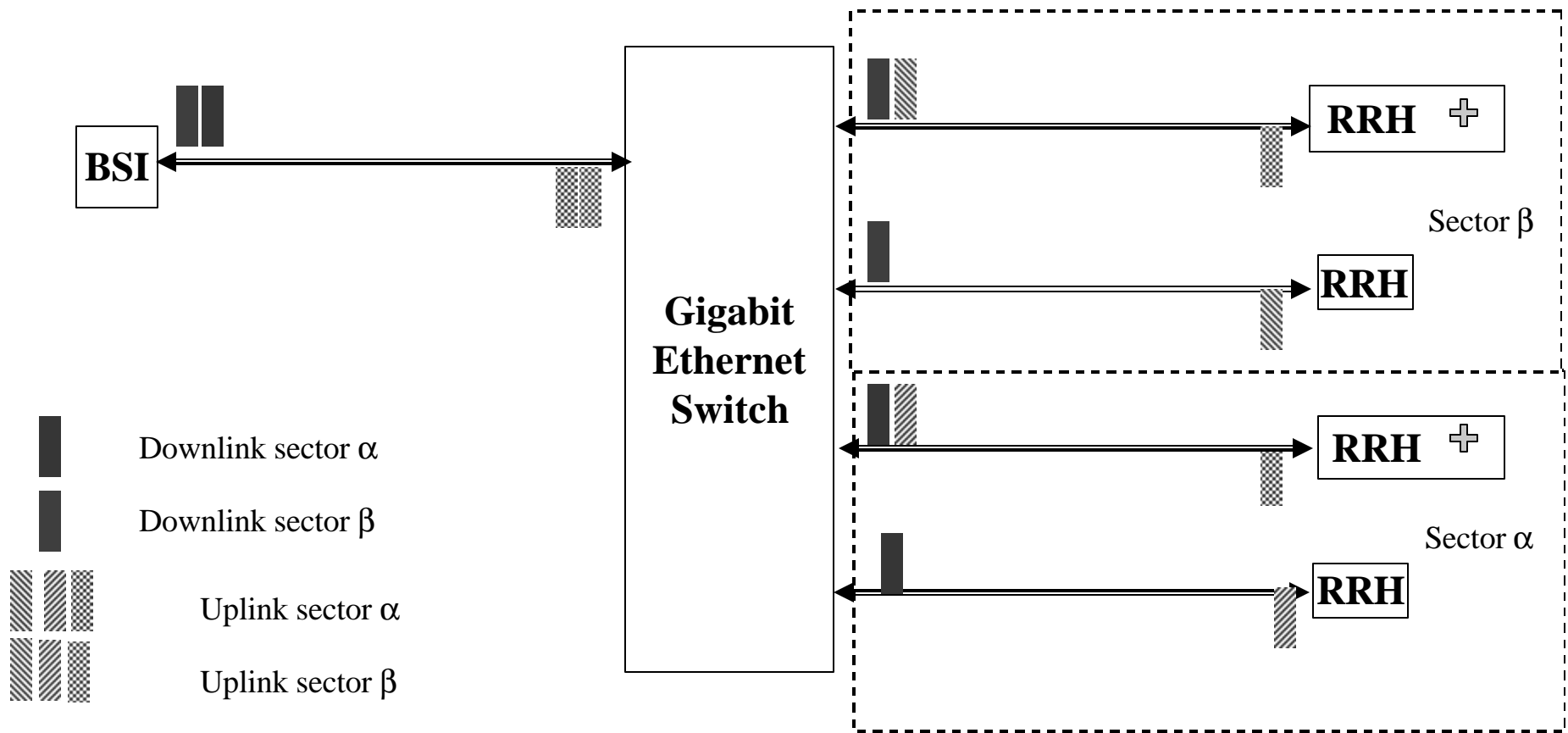

Cellular over Gigabit Ethernet

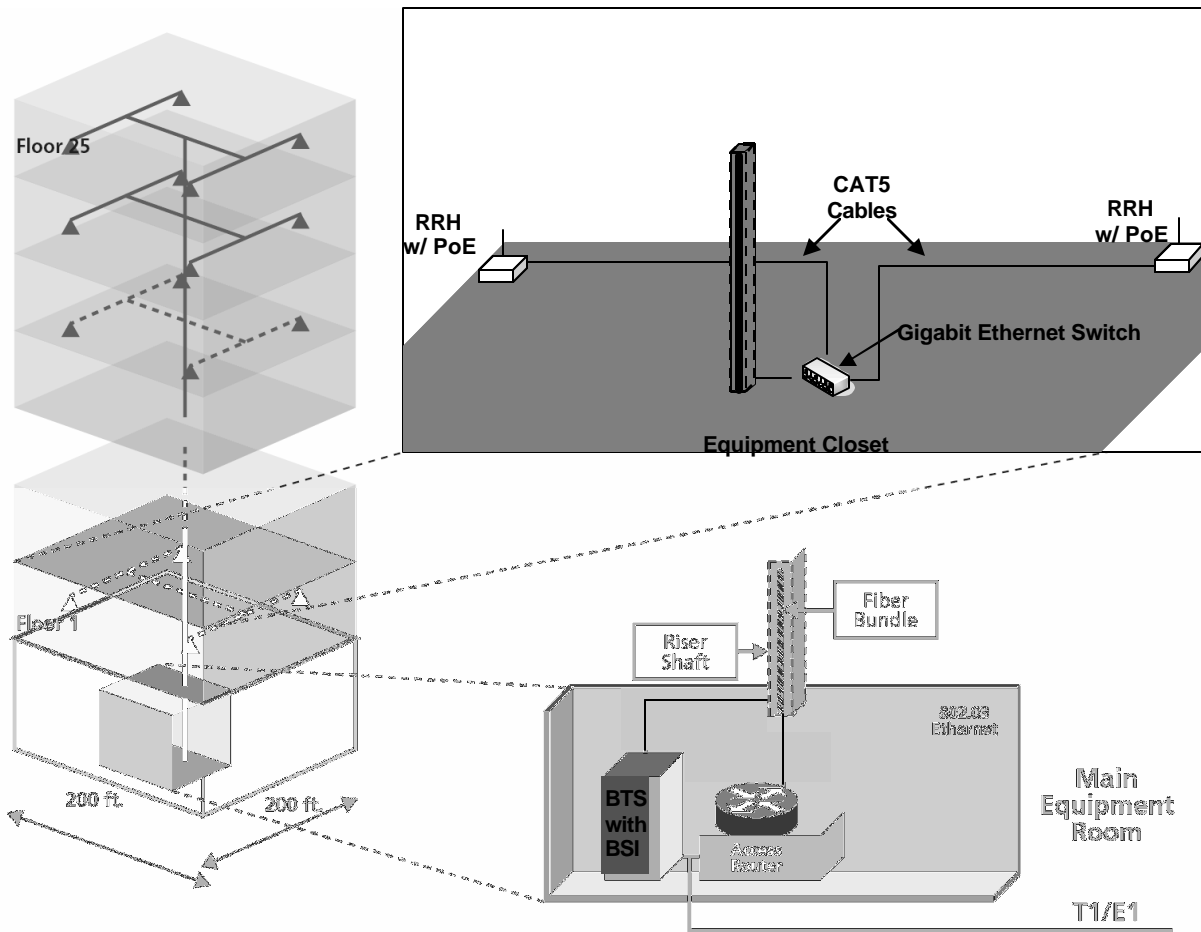

Digitized CDMA/UMTS/GSM RF signal is distributed in-building through switched Gigabit Ethernet packet data network using LAN CAT5/fiber cables (potentially existing). Same system can transport CDMA 1X, EV-DO, or UMTS signals.

Interface to BTS through baseband I/Q or RF radio input and output. (no modification of BTS required)

Remote Radio Heads (RRHs) based on handset technology and powered over CAT5 cable radiate downlink signal and receives uplink signal.

Macrocellular distribution

Radio distribution for outdoor macrocells and hot spots [Hoteling]

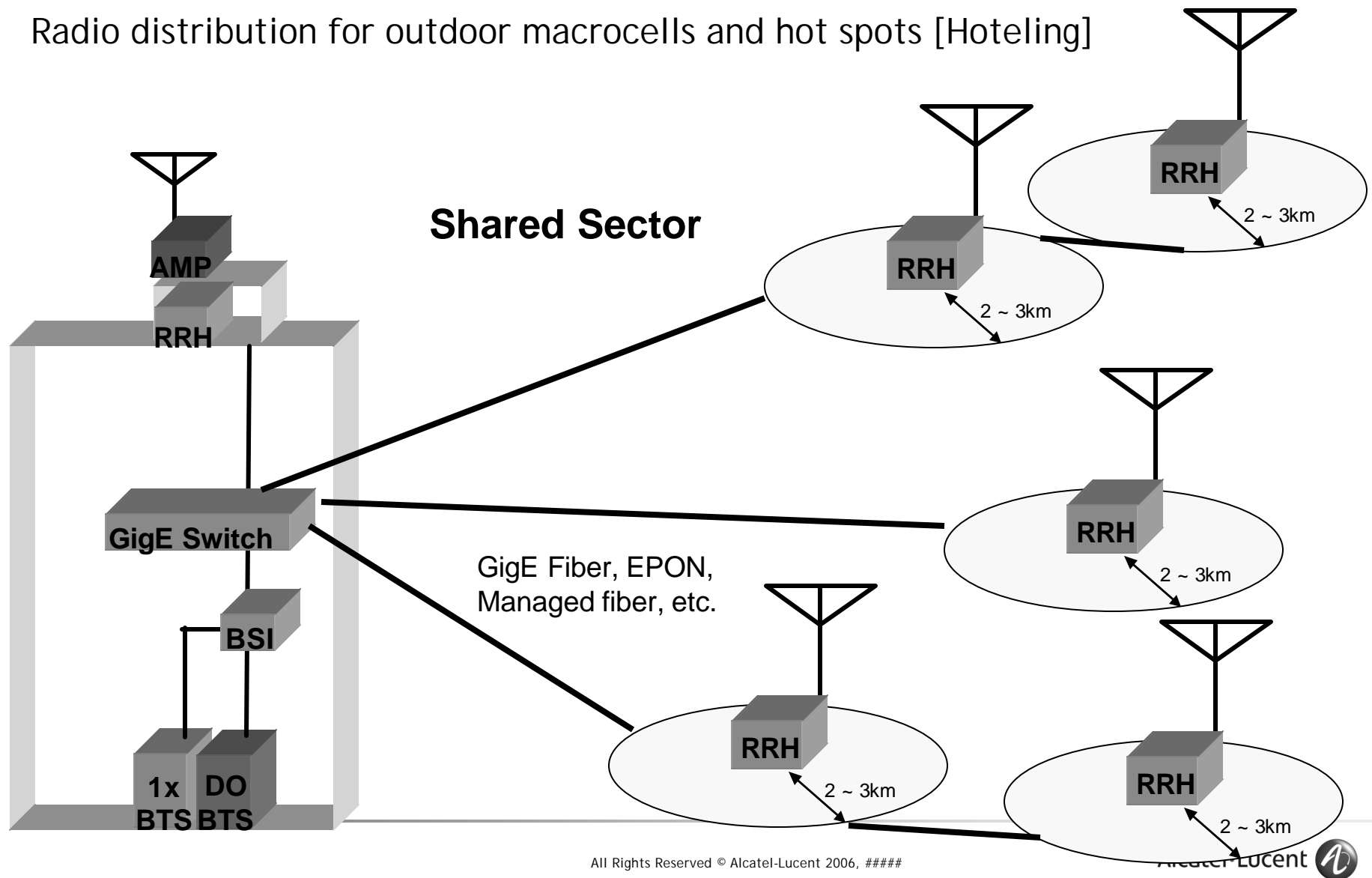

Scalable Network

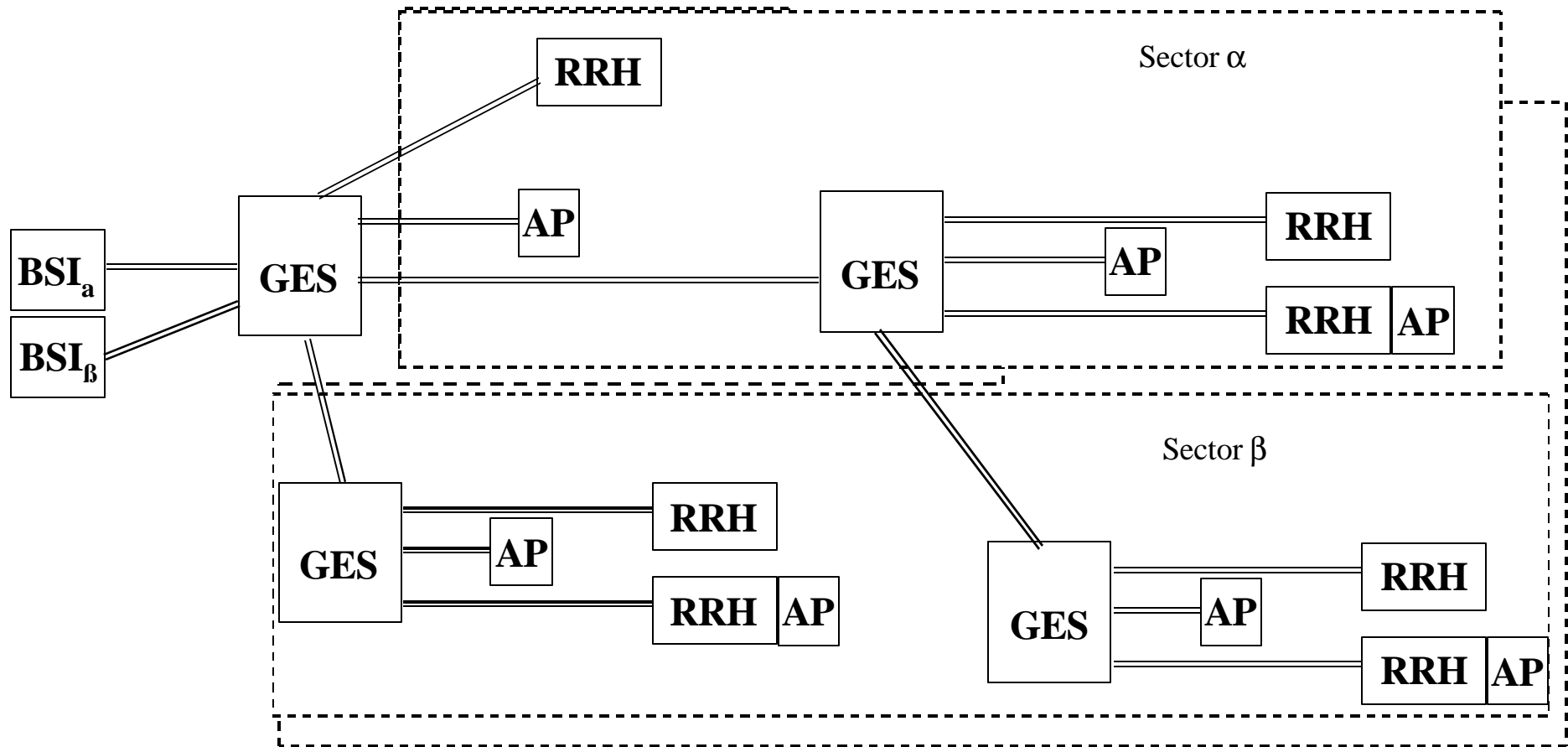

BSI: base station interface
RRH: remote radio Head

GES: gigabit Ethernet switch
AP: 802.11 access point

Direct BTS Driven Application



A BTS or at least one sector of a BTS is dedicated to driving the network for either in-building coverage or hoteling of BTS's

The BTS interface would be RF initially, but can be digital CPRI or built into BTS.

Delay in downlink can be compensated by timing advancement in BTS

Off-the-shelf GigE switches can be used in the network

RF Repeater Application

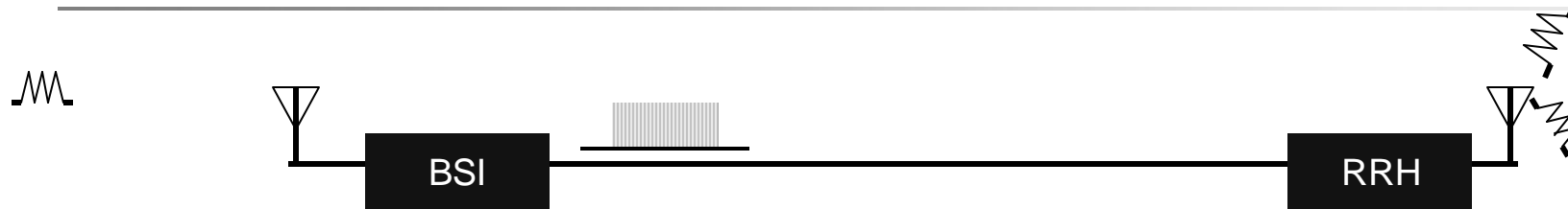

Signals received over the air for re-broadcasting over desired coverage area

Requires very small delay to avoid upsetting air-interface (standard calls for < 5 us)

Conclusion

Market Opportunity

- The In-building market for wireless coverage is growing and with easy to install and cost effective solutions such as we have presented here will accelerate.
- Hoteling for macrocellular coverage has clear advantages which can be enabled with this technology

Key advantages to this approach

- Take advantage of Gigabit ethernet equipments, components and CAT5/fiber medium
- Software sectorization for capacity management and growth
- Intelligent management of reverse-link for interference protection
- Transport RF bandwidth: air-interface agnostic and future proof.