

Name \_\_\_\_\_

CSE 241 Digital Systems

Hourly Exam #2

Nov 13, 2009

*Instructions: Write your name on the top of each sheet. Show all work in the space provided. No calculators or other electronic devices allowed. 50 min closed book.*

1. For the Boolean function  $f(w,x,y,z) = y'z' + xz' + wx'z' + w'x'z$

(a) Fill in the Karnaugh Map, showing all prime implicant subcubes

(b) List all prime implicants

--

(c) Write all irredundant sums

--

2.

$$f(v,w,x,y,z) = (v+w)(x+y)(z)$$

Use the Quine-McCluskey Method to express the Boolean function  $f(v,w,x,y,z)$  as a sum of all its prime implicants. Show all your work. *Note: do not worry about redundant prime implicants. Not necessary to construct a prime implicant table or use Petrick Method. Just find all the prime implicants using the QM method.*

Express  $f(v,w,x,y,z)$  as the sum of all its prime implicants:

$f(v,w,x,y,z) =$  \_\_\_\_\_

Name \_\_\_\_\_

3. A circuit with output  $f(x,y,z)$  which uses a 8-to-1 MUX is shown. Design a circuit producing exactly the same output  $f(x,y,z)$  but which uses a smaller 4-to-1 MUX. Use  $x$  and  $z$  as the select input line variables as shown. Label the data inputs.

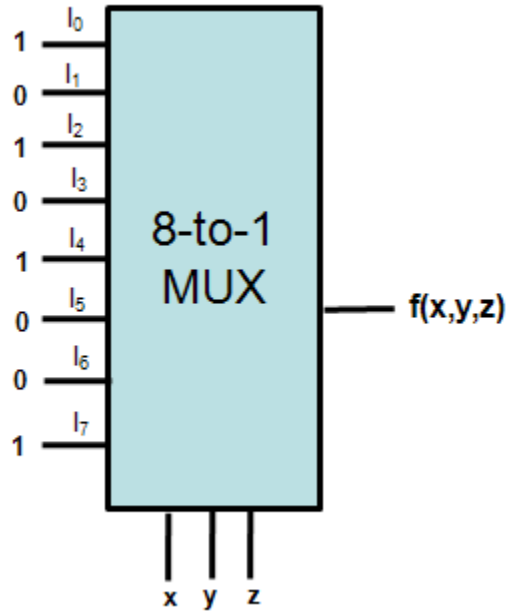

3.

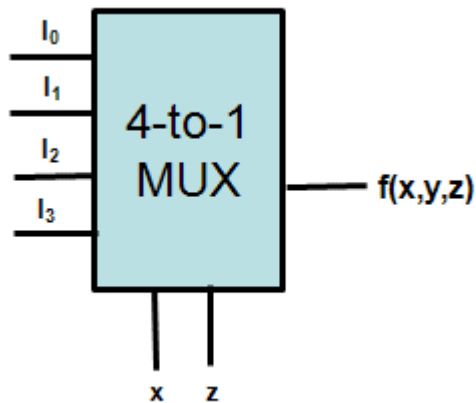

4. As discussed in the text and in lecture, a 1-bit comparator has three outputs

$$G_{i+1} = A_i B_i' + A_i G_i + B_i' G_i$$

$$E_{i+1} = (A_i' B_i' + A_i B_i) E_i$$

$$L_{i+1} = A_i' B_i + B_i L_i + A_i' L_i$$

where  $G_i=1$  if " $A_i A_{i-1} \dots A_0$ " > " $B_i B_{i-1} \dots B_0$ ",  $E_i=1$  if they are equal, and  $L_i=1$  otherwise.

(a) Using a 5-to-32 decoder to build a 1-bit comparator, we will need one additional OR gate for each of the three outputs  $G_{i+1}$ ,  $E_{i+1}$ ,  $L_{i+1}$ . Specify how many inputs each of these OR gates will require, ie. how many lines will connect each of these three OR gates to the decoder. Show your reasoning.

(b) A 2-bit comparator compares two bits " $A_{i1} A_{i0}$ " and " $B_{i1} B_{i0}$ " at a time instead of just one as with the 1-bit comparator above. Let G, E and L be as above except  $G_{i+1}=1$  if

$$"A_{i1} A_{i0} A_{(i-1)1} A_{(i-1)0} \dots A_{01} A_{00}" > "B_{i1} B_{i0} B_{(i-1)1} B_{(i-1)0} \dots B_{01} B_{00}",$$

$E_{i+1}=1$  if they are equal, and otherwise  $L_{i+1}=1$ . Write formulas similar to those on the top of this page for the three outputs  $G_{i+1}$ ,  $E_{i+1}$ ,  $L_{i+1}$  of a 2-bit comparator. Note that your formulas should involve  $A_{i1}$ ,  $A_{i0}$ ,  $B_{i1}$  and  $B_{i0}$  instead of  $A_i$  and  $B_i$ .

(a) The  $G_{i+1}$  OR gate will have \_\_\_\_\_ inputs

The  $E_{i+1}$  OR gate will have \_\_\_\_\_ inputs

The  $L_{i+1}$  OR gate will have \_\_\_\_\_ inputs

(b)  $G_{i+1} =$  \_\_\_\_\_

$E_{i+1} =$  \_\_\_\_\_

$L_{i+1} =$  \_\_\_\_\_