

Virtual Memory Management

B.Ramamurthy
Chapter 10

Paging

The relation between virtual addresses and physical memory addresses given by page table

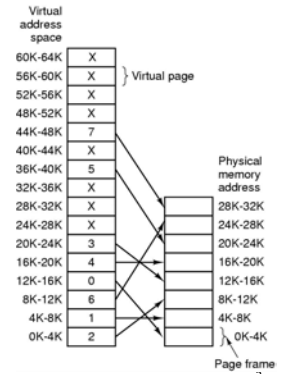

Demand Paging (contd.)

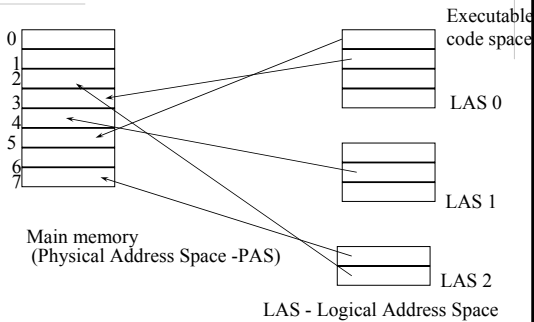

Page Tables (1)

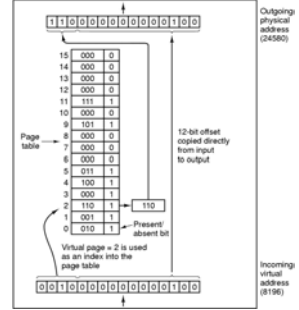

Internal operation of MMU with 16 4 KB pages 4

Page Tables (2)

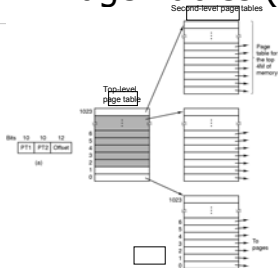

- 32 bit address with 2 page table fields
- Two-level page tables

Page Tables (3)

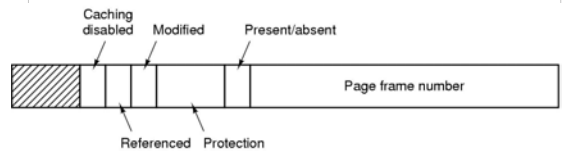

Typical page table entry

TLBs – Translation Lookaside Buffers

Valid	Virtual page	Modified	Protection	Page frame
1	140	1	RW	31
1	20	0	R X	38
1	130	1	RW	29
1	129	1	RW	62
1	19	0	R X	50
1	21	0	R X	45
1	860	1	RW	14
1	861	1	RW	75

A TLB to speed up paging

7

Inverted Page Tables

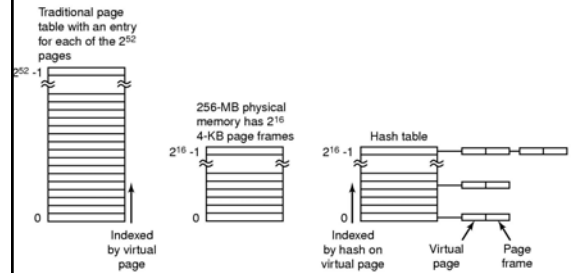

Comparison of a traditional page table with an inverted page table

8

Page Fault Handling (1)

- Hardware traps to kernel
- General registers saved
- OS determines which virtual page needed
- OS checks validity of address, seeks page frame
- If selected frame is dirty, write it to disk

9

Page Fault Handling (2)

- OS brings schedules new page in from disk
- Page tables updated
- Faulting instruction backed up to when it began
- Faulting process scheduled
- Registers restored
- Program continues

10

Locking Pages in Memory

- Virtual memory and I/O occasionally interact
- Proc issues call for read from device into buffer
 - while waiting for I/O, another processes starts up
 - has a page fault
 - buffer for the first proc may be chosen to be paged out
- Need to specify some pages locked
 - exempted from being target pages

11

Backing Store

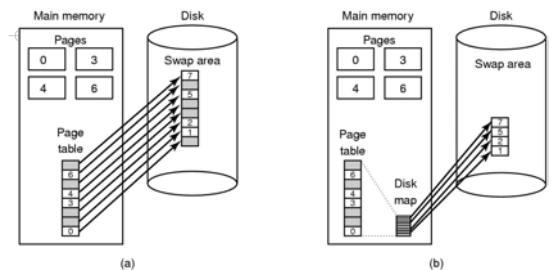

(a) Paging to static swap area
(b) Backing up pages dynamically

12

Sharing Pages: a text editor

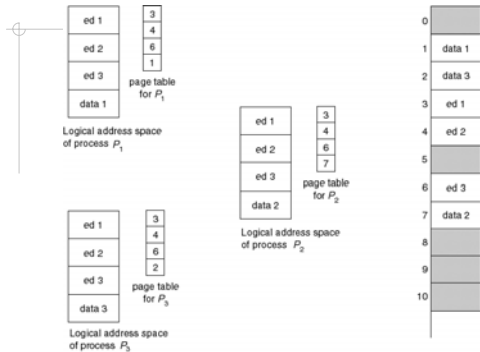

13

Implementation Issues

Operating System Involvement with Paging
Four times when OS involved with paging

1. Process creation
 - determine program size
 - create page table
2. Process execution
 - MMU reset for new process
 - TLB flushed
3. Page fault time
 - determine virtual address causing fault
 - swap target page out, needed page in
4. Process termination time
 - release page table, pages

14

Page Replacement Algorithms

- ✦ Page fault forces choice
 - which page must be removed
 - make room for incoming page
- ✦ Modified page must first be saved
 - unmodified just overwritten
- ✦ Better not to choose an often used page
 - will probably need to be brought back in soon

15

Optimal Page Replacement Algorithm

- ✦ Replace page needed at the farthest point in future
 - Optimal but unrealizable
- ✦ Estimate by ...
 - logging page use on previous runs of process
 - although this is impractical

16

Not Recently Used Page Replacement Algorithm

- ✦ Each page has Reference bit, Modified bit
 - bits are set when page is referenced, modified
- ✦ Pages are classified
 1. not referenced, not modified
 2. not referenced, modified
 3. referenced, not modified
 4. referenced, modified
- ✦ NRU removes page at random
 - from lowest numbered non empty class

17

FIFO Page Replacement Algorithm

- ✦ Maintain a linked list of all pages
 - in order they came into memory
- ✦ Page at beginning of list replaced
- ✦ Disadvantage
 - page in memory the longest may be often used

18

The Clock Page Replacement Algorithm

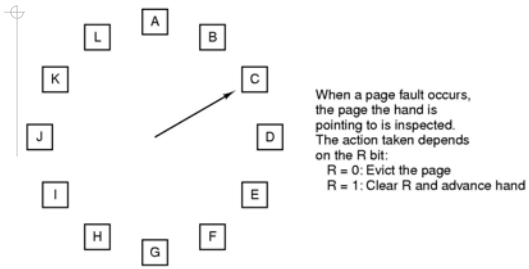

19

Least Recently Used (LRU)

- Assume pages used recently will be used again soon
 - throw out page that has been unused for longest time
- Must keep a linked list of pages
 - most recently used at front, least at rear
 - update this list every memory reference !!
- Alternatively keep counter in each page table entry
 - choose page with lowest value counter
 - periodically zero the counter

20

Simulating LRU in Software (1)

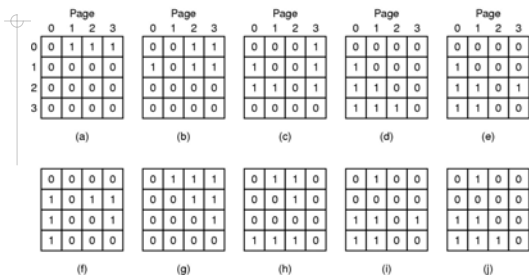

LRU using a matrix – pages referenced in order
0,1,2,3,2,1,0,3,2,3

21

Simulating LRU in Software (2)

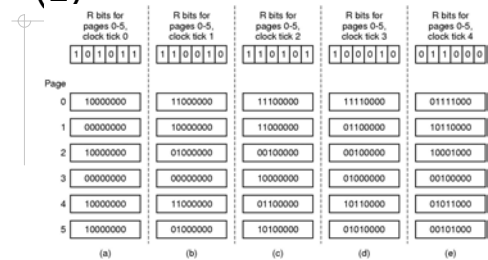

- The aging algorithm simulates LRU in software
- Note 6 pages for 5 clock ticks, (a) – (e)

22

Working-Set Model

- Δ = working-set window = a fixed number of page references
Example: 10,000 instruction
- WSS_P (working set of Process P) = total number of pages referenced in the most recent Δ (varies in time)
 - if Δ too small will not encompass entire locality.
 - if Δ too large will encompass several localities.
 - if $\Delta = \infty \Rightarrow$ will encompass entire program.
- $D = \sum WSS_P$ = total demand frames
- if $D > m \Rightarrow$ Thrashing
- Policy if $D > m$, then suspend one of the processes.

23

Working-set model

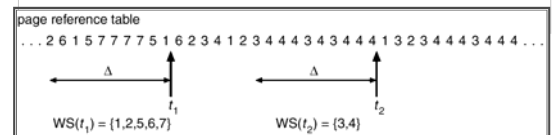

24

Keeping Track of the Working Set

- Approximate with interval timer + a reference bit
- Example: $\Delta = 10,000$
 - Timer interrupts after every 5000 time units.
 - Keep in memory 2 bits for each page.
 - Whenever a timer interrupts copy and sets the values of all reference bits to 0.
 - If one of the bits in memory = 1 \Rightarrow page in working set.
- Why is this not completely accurate?
- Improvement = 10 bits and interrupt every 1000 time units.

25

The Working Set Page Replacement Algorithm (1)

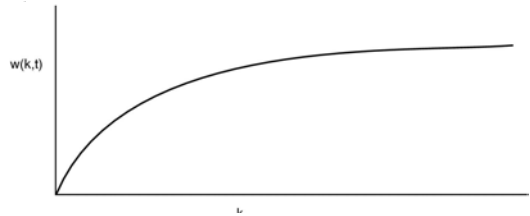

- The working set is the set of pages used by the k most recent memory references
- $w(k,t)$ is the size of the working set at time, t

26

The Working Set Page Replacement Algorithm (2)

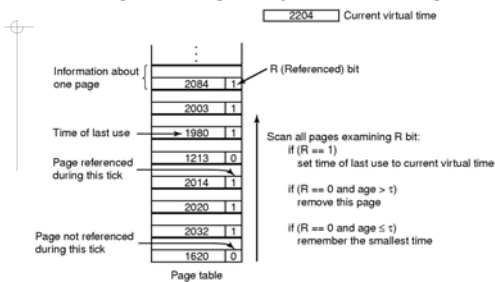

The working set algorithm

27

The WSclock Page Replacement Algorithm

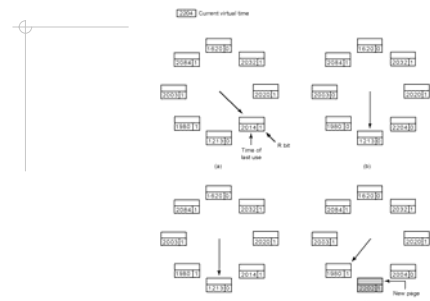

Operation of the WSclock algorithm

28

Review of Page Replacement Algorithms

Algorithm	Comment
Optimal	Not implementable, but useful as a benchmark
NRU (Not Recently Used)	Very crude
FIFO (First-In, First-Out)	Might throw out important pages
Second chance	Big improvement over FIFO
Clock	Realistic
LRU (Least Recently Used)	Excellent, but difficult to implement exactly
NFU (Not Frequently Used)	Fairly crude approximation to LRU
Aging	Efficient algorithm that approximates LRU well
Working set	Somewhat expensive to implement
WSclock	Good efficient algorithm

29

Modeling Page Replacement Algorithms Belady's Anomaly

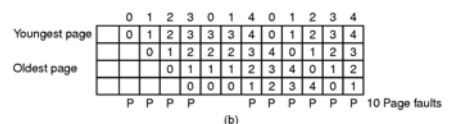
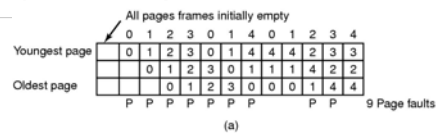

- FIFO with 3 page frames
- FIFO with 4 page frames
- P 's show which page references show page faults

30

