

Memory Management

Lectures notes from the text supplement by Siberschatz and Galvin Modified by B.Ramamurthy Chapter 9

Binding of Instructions and Data to Memory

Address binding of instructions and data to memory addresses can happen at three different stages.

- **Compile time:** If memory location known a priori, absolute code can be generated; must recompile code if starting location changes.
- **Load time:** Must generate *relocatable* code if memory location is not known at compile time.
- **Execution time:** Binding delayed until run time if the process can be moved during its execution from one memory segment to another. Need hardware support for address maps (e.g., *base* and *limit registers*).

Dynamic relocation using a relocation register

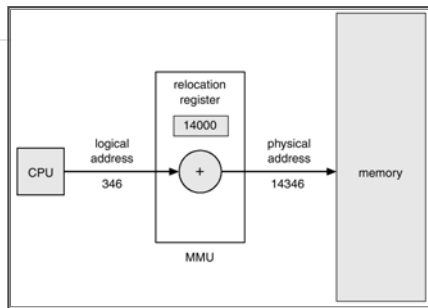

Dynamic Loading

- Routine is not loaded until it is called
- Better memory-space utilization; unused routine is never loaded.
- Useful when large amounts of code are needed to handle infrequently occurring cases.
- No special support from the operating system is required implemented through program design.

Dynamic Linking

- Linking postponed until execution time.
- Small piece of code, *stub*, used to locate the appropriate memory-resident library routine.
- Stub replaces itself with the address of the routine, and executes the routine.
- Operating system needed to check if routine is in processes' memory address.
- Dynamic linking is particularly useful for libraries.

Overlays

- Keep in memory only those instructions and data that are needed at any given time.
- Needed when process is larger than amount of memory allocated to it.
- Implemented by user, no special support needed from operating system, programming design of overlay structure is complex

Swapping

- A process can be *swapped* temporarily out of memory to a *backing store*, and then brought back into memory for continued execution.
- Backing store – fast disk large enough to accommodate copies of all memory images for all users; must provide direct access to these memory images.
- *Roll out, roll in* – swapping variant used for priority-based scheduling algorithms; lower-priority process is swapped out so higher-priority process can be loaded and executed.

10/22/2003

7

Schematic View of Swapping

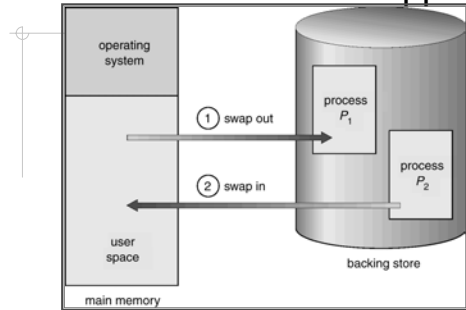

10/22/2003

8

Contiguous Allocation

- Main memory usually into two partitions:
 - Resident operating system, usually held in low memory with interrupt vector.
 - User processes then held in high memory.
- Single-partition allocation
 - Relocation-register scheme used to protect user processes from each other, and from changing operating-system code and data.
 - Relocation register contains value of smallest physical address; limit register contains range of logical addresses – each logical address must be less than the limit register.

10/22/2003

9

Hardware Support for Relocation and Limit Registers

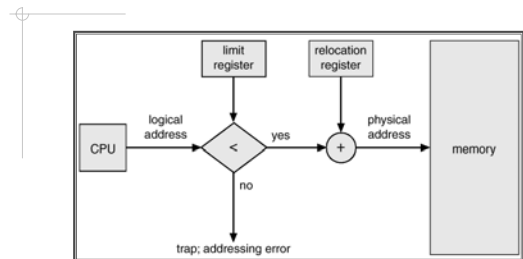

10/22/2003

10

Contiguous Allocation (Cont.)

- Multiple-partition allocation
 - *Hole* – block of available memory; holes of various size are scattered throughout memory.
 - When a process arrives, it is allocated memory from a hole large enough to accommodate it.
 - Operating system maintains information about:
 - a) allocated partitions
 - b) free partitions (hole)

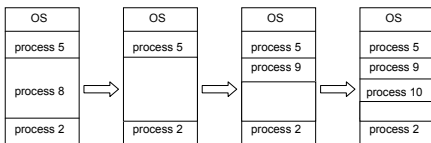

10/22/2003

11

Dynamic Storage-Allocation Problem

How to satisfy a request of size n from a list of free holes.

- **First-fit:** Allocate the *first* hole that is big enough.
- **Best-fit:** Allocate the *smallest* hole that is big enough; must search entire list, unless ordered by size. Produces the smallest leftover hole.
- **Worst-fit:** Allocate the *largest* hole; must also search entire list. Produces the largest leftover hole.

First-fit and best-fit better than worst-fit in terms of speed and storage utilization.

10/22/2003

12

Fragmentation

- **External Fragmentation** – total memory space exists to satisfy a request, but it is not contiguous.
- **Internal Fragmentation** – allocated memory may be slightly larger than requested memory; this size difference is memory internal to a partition, but not being used.
- Reduce external fragmentation by compaction
 - Shuffle memory contents to place all free memory together in one large block.
 - Compaction is possible *only* if relocation is dynamic, and is done at execution time.
 - I/O problem
 - Latch job in memory while it is involved in I/O.
 - Do I/O only into OS buffers.

10/22/2003

13

Paging

- Logical address space of a process can be noncontiguous; process is allocated physical memory whenever the latter is available.
- Divide physical memory into fixed-sized blocks called **frames** (size is power of 2, between 512 bytes and 8192 bytes).
- Divide logical memory into blocks of same size called **pages**.
- Keep track of all free frames.
- To run a program of size n pages, need to find n free frames and load program.
- Set up a page table to translate logical to physical addresses.
- Internal fragmentation.

10/22/2003

14

Address Translation Scheme

- Address generated by CPU is divided into:
 - **Page number (p)** – used as an index into a **page table** which contains base address of each page in physical memory.
 - **Page offset (d)** – combined with base address to define the physical memory address that is sent to the memory unit.

10/22/2003

15

Address Translation Architecture

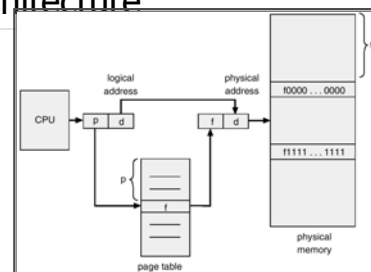

10/22/2003

16

Paging Example

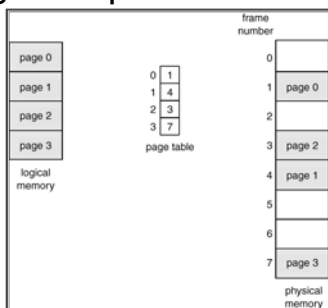

10/22/2003

17

Paging Example

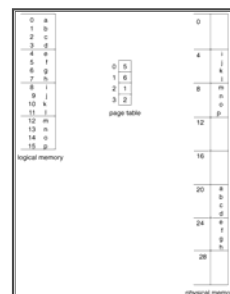

10/22/2003

18

Free Frames

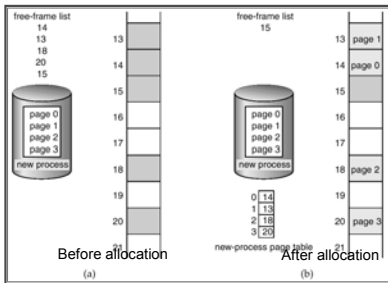

10/22/2003

19

Implementation of Page Table

- Page table is kept in main memory.
- *Page-table base register (PTBR)* points to the page table.
- *Page-table length register (PRLR)* indicates size of the page table.
- In this scheme every data/instruction access requires two memory accesses. One for the page table and one for the data/instruction.
- The two memory access problem can be solved by the use of a special fast-lookup hardware cache called *associative memory* or *translation look-aside buffers (TLBs)*

10/22/2003

20

Paging Hardware With TLB

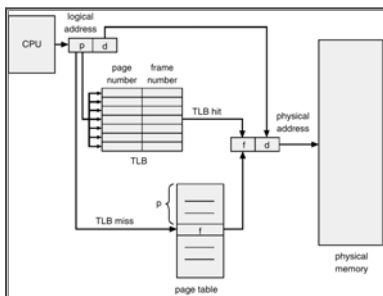

10/22/2003

21

Effective Access Time

- Associative Lookup = ϵ time unit
- Assume memory cycle time is 1 microsecond
- Hit ratio – percentage of times that a page number is found in the associative registers; ration related to number of associative registers.
- Hit ratio = α
- Effective Access Time (EAT)

$$EAT = (1 + \epsilon) \alpha + (2 + \epsilon)(1 - \alpha) \\ = 2 + \epsilon - \alpha$$

10/22/2003

22

Inverted Page Table

- One entry for each real page of memory.
- Entry consists of the virtual address of the page stored in that real memory location, with information about the process that owns that page.
- Decreases memory needed to store each page table, but increases time needed to search the table when a page reference occurs.
- Use hash table to limit the search to one — or at most a few — page-table entries.

10/22/2003

23

Inverted Page Table Architecture

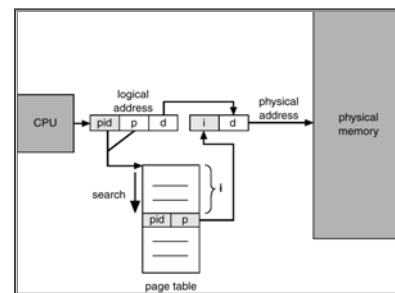

10/22/2003

24