

System Calls

B.Ramamurthy (Adapted from
Tannenbaum's text)

Introduction

- ◆ System calls: The mechanism used by an application program to request service from the operating system. System calls often use a special machine code instruction which causes the processor to change mode (e.g. to "supervisor mode" or "protected mode"). This allows the OS to perform restricted actions such as accessing hardware devices or the memory management unit.

From The Free Online Dictionary of Computing (<http://foldoc.doc.ic.ac.uk/>) is edited by Denis Howe <dbh@doc.ic.ac.uk>.

Steps in Making a System Call

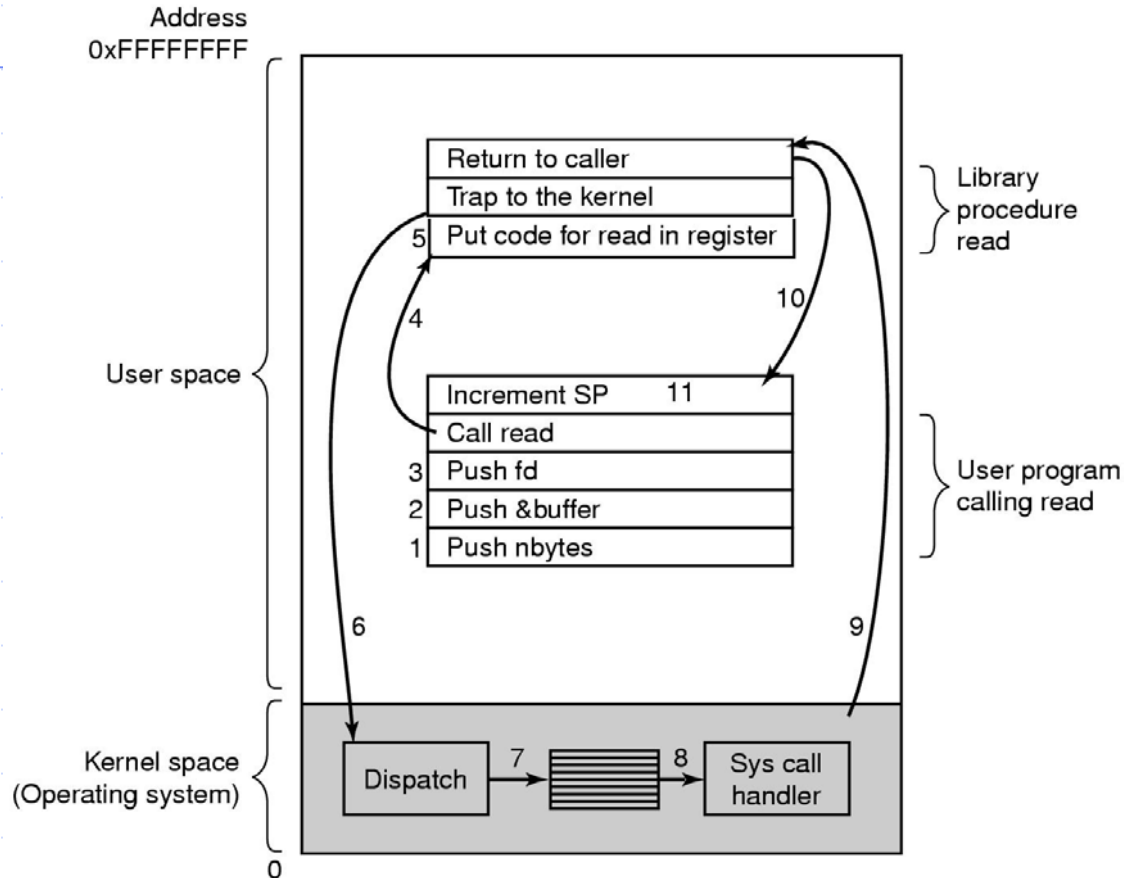

There are 11 steps in making the system call read (fd, buffer, nbytes)

Some System Calls For Process Management

Process management

Call	Description
<code>pid = fork()</code>	Create a child process identical to the parent
<code>pid = waitpid(pid, &statloc, options)</code>	Wait for a child to terminate
<code>s = execve(name, argv, environp)</code>	Replace a process' core image
<code>exit(status)</code>	Terminate process execution and return status

Some System Calls For File Management

File management

Call	Description
<code>fd = open(file, how, ...)</code>	Open a file for reading, writing or both
<code>s = close(fd)</code>	Close an open file
<code>n = read(fd, buffer, nbytes)</code>	Read data from a file into a buffer
<code>n = write(fd, buffer, nbytes)</code>	Write data from a buffer into a file
<code>position = lseek(fd, offset, whence)</code>	Move the file pointer
<code>s = stat(name, &buf)</code>	Get a file's status information

Some System Calls For Directory Management

Directory and file system management

Call	Description
s = mkdir(name, mode)	Create a new directory
s = rmdir(name)	Remove an empty directory
s = link(name1, name2)	Create a new entry, name2, pointing to name1
s = unlink(name)	Remove a directory entry
s = mount(special, name, flag)	Mount a file system
s = umount(special)	Unmount a file system

Some System Calls For Miscellaneous Tasks

Miscellaneous

Call	Description
<code>s = chdir(dirname)</code>	Change the working directory
<code>s = chmod(name, mode)</code>	Change a file's protection bits
<code>s = kill(pid, signal)</code>	Send a signal to a process
<code>seconds = time(&seconds)</code>	Get the elapsed time since Jan. 1, 1970

System Calls (5)

UNIX	Win32	Description
fork	CreateProcess	Create a new process
waitpid	WaitForSingleObject	Can wait for a process to exit
execve	(none)	CreateProcess = fork + execve
exit	ExitProcess	Terminate execution
open	CreateFile	Create a file or open an existing file
close	CloseHandle	Close a file
read	ReadFile	Read data from a file
write	WriteFile	Write data to a file
lseek	SetFilePointer	Move the file pointer
stat	GetFileAttributesEx	Get various file attributes
mkdir	CreateDirectory	Create a new directory
rmdir	RemoveDirectory	Remove an empty directory
link	(none)	Win32 does not support links
unlink	DeleteFile	Destroy an existing file
mount	(none)	Win32 does not support mount
umount	(none)	Win32 does not support mount
chdir	SetCurrentDirectory	Change the current working directory
chmod	(none)	Win32 does not support security (although NT does)
kill	(none)	Win32 does not support signals
time	GetLocalTime	Get the current time

Some Win32 API calls

Operating systems

- ◆ The OS may be split into a kernel which is always present and various system programs which use facilities provided by the kernel to perform higher-level house-keeping tasks, often acting as servers in a client-server relationship.

Operating System Structure

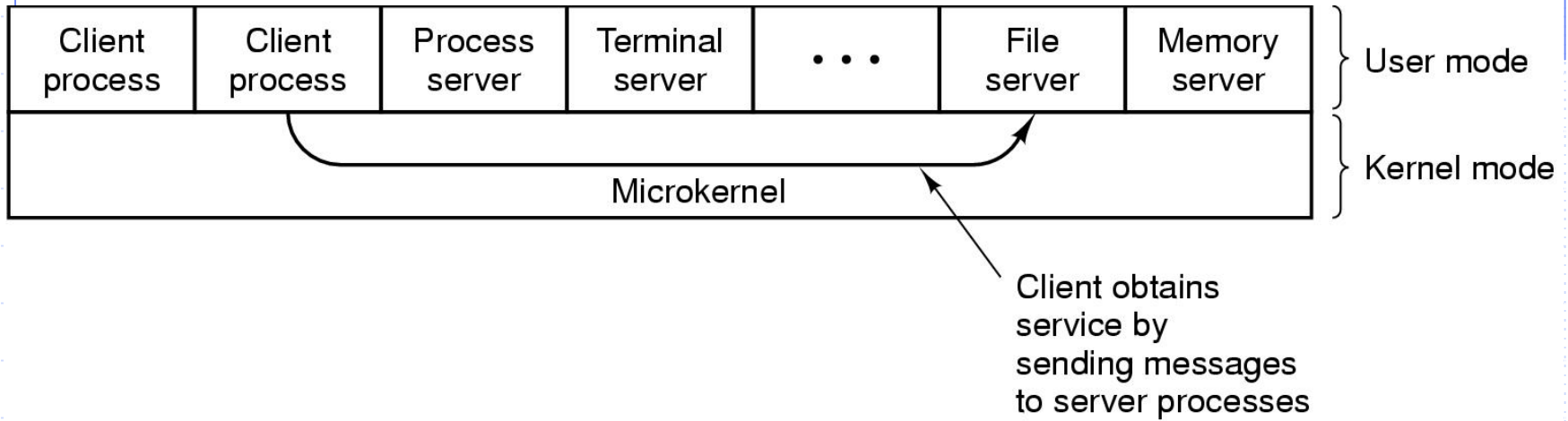

The client-server model

Operating System Structure

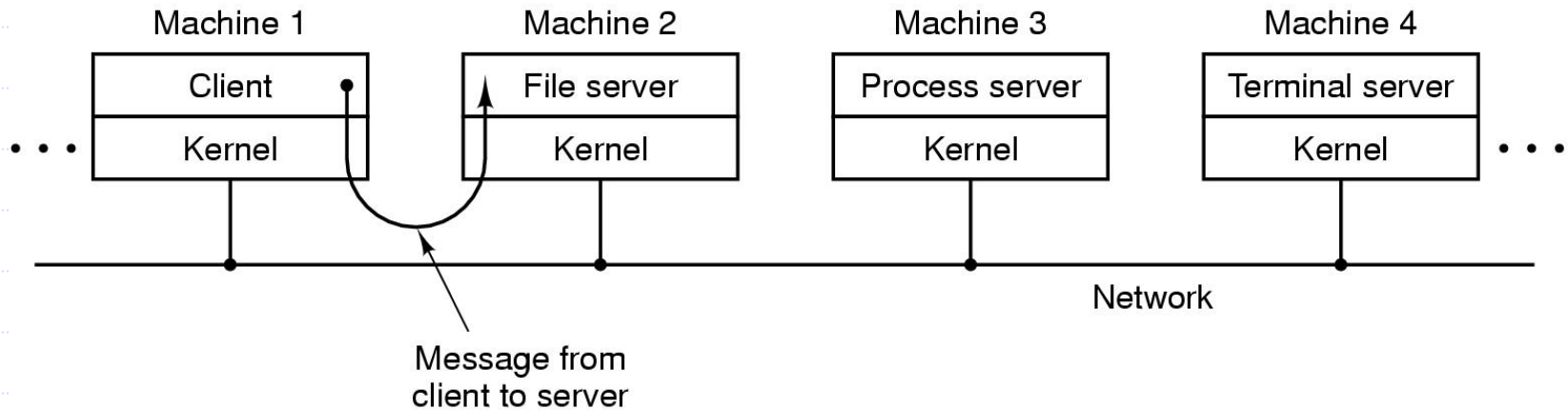

The client-server model in a distributed system

Summary

- ◆ We studied the importance of system calls.
- ◆ And the structure of modern operating systems: client/server and distributed.